

4.2 Winch Assembly

Fig. No.	Name	Dwg. No.	Qty. per Assy.
0	Winch Assembly		1
1	Pulley Mount LH	5099901	1
2	Rear Mounting Bracket	5099902	2
3	Front Mounting Bracket	5099903	1
4	Pulley Mount RH	5099904	1
5	Winch Base Modification	5065305	1
6	Pulley Bushing	5099906	3
7	Pulley Spacer	5099907	6
8	Wire Rope Clip	9003702	2
9	Pulley	9010601	3
10	Cable	9004002	20'

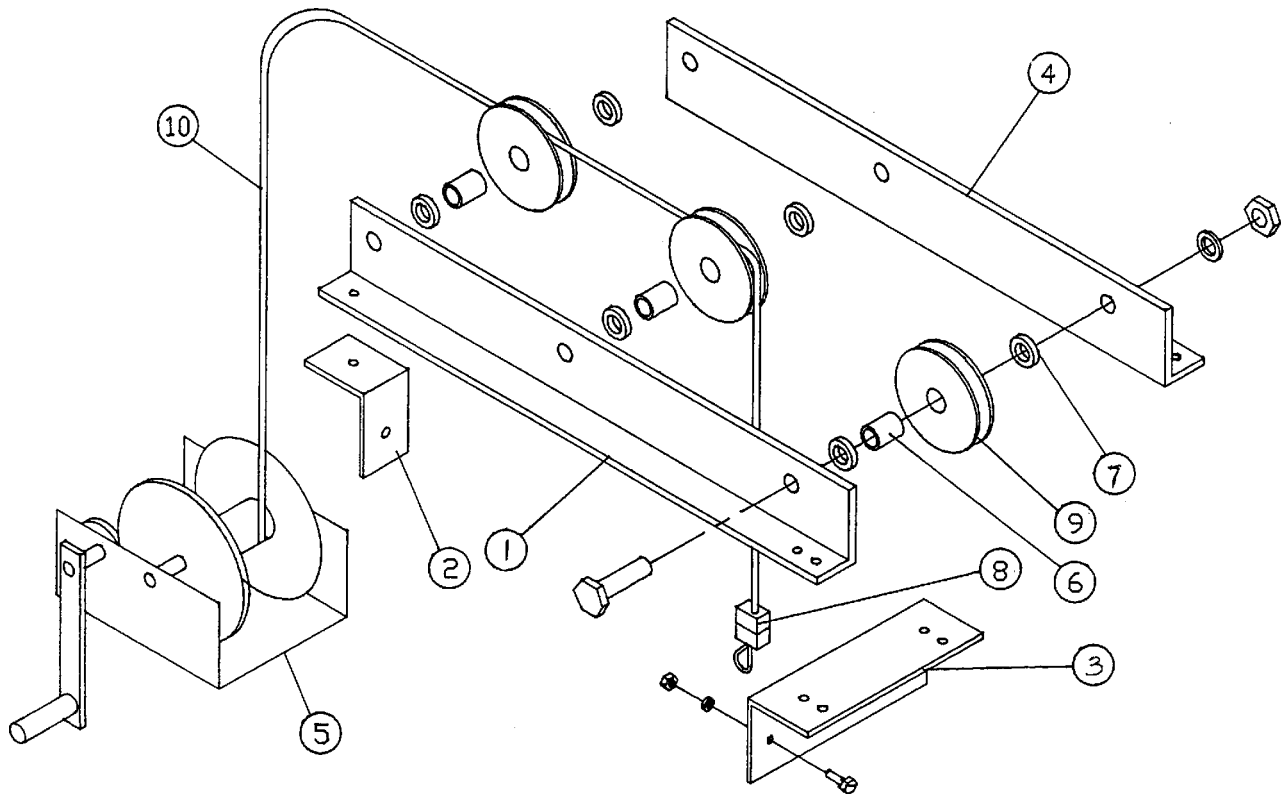

Winch Assembly

4.3 Trolley Beam Assembly

Fig. No.	Name	Dwg. No.	Qty. per Assy.
0	Trolley Beam Assembly	50973	
1	Trolley Beam Sub Assy.	50972	1
5	End Stop	52306-02	4
6	Spring Washer	9012713	8
7	Nut	9093433	4
8	Bolt	9093147	4
9	Eye Bolt	9010002	1
10	Threaded Connector	9010101	1
11	Nut	9003903	1

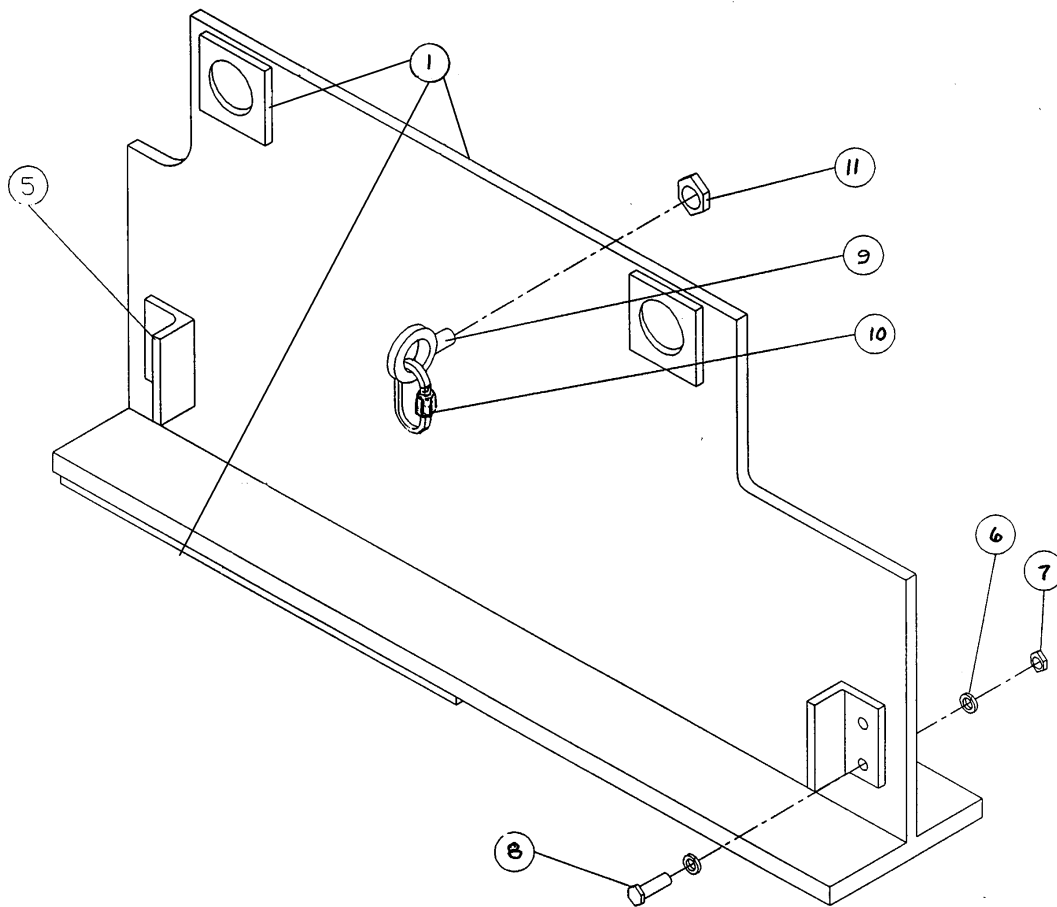

Trolley Beam Assembly

4.4 Link Support

Fig. No.	Name	Dwg. No.	Qty. per Assy.
1	Link Support	50614	1

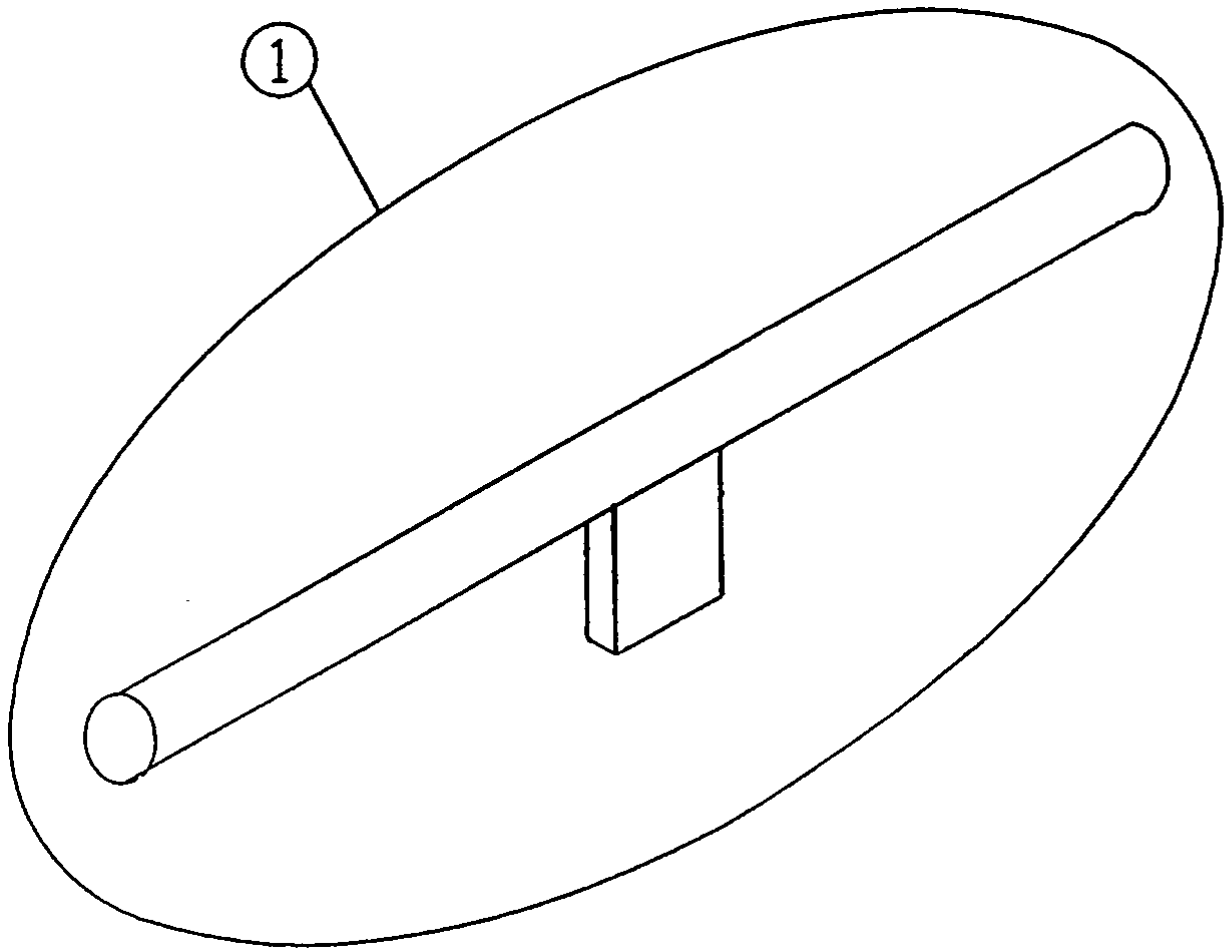

4.5 Electro-Hydraulic Base Assembly for Dynamic Option

Fig. No.	Name	Dwg. No.	Qty. per Assy.
0	Electro-Hydraulic Base Assembly for Dynamic Option	50921	1
4	Front Support	509204	1
6	DHLT Stand Cover Hyd.	50923	1

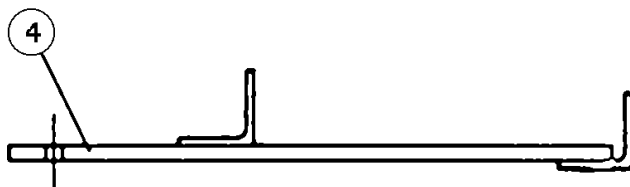
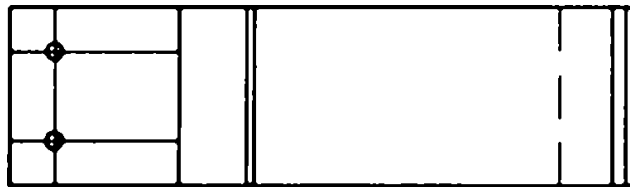
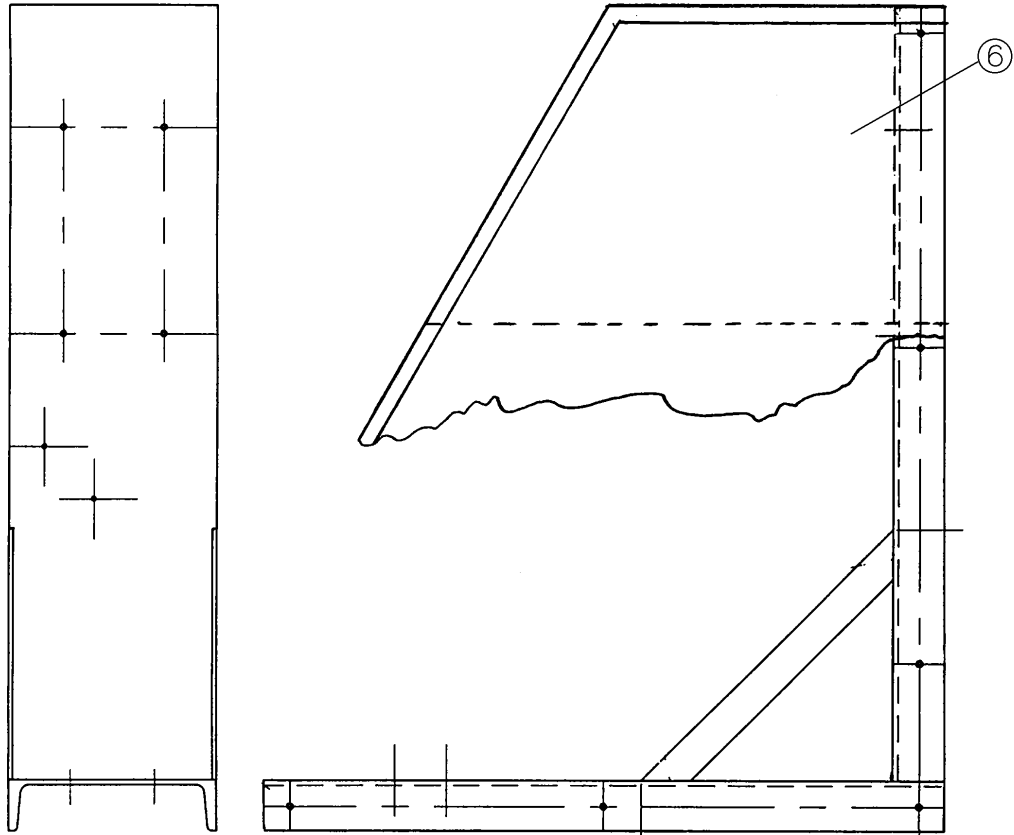

4.6 English/Metric Tester Frame Assembly

Fig. No.	Name	Dwg. No.	Qty. per Assy.	Notes
0	Tester Frame Assembly	50979	1	
1	Top Beam Assembly	50980	1	
2	Column Assembly	50955	1	
3	Cylinder Mount	50950	1	
4	Lower Beam Assembly	50954	1	
5	Base Assembly	50554	1	
6	Outrigger Assembly	50558	2	
7	Pin	5055302	3	
8	Pin	5055301	2	
9	Master Link	9010201	2	
10	Master Link	9010202	2	
11	Trolley Test Beam Assy.	50973	1	
12	"I" Taper Washer	9043522	6	M20
13	Bolt	90931135	6	M20 x 46 x 80
14	Lock Washer	9012717	6	M20
15	Nut	9093445	18	M20 x 2.5
16	Bolt	9093192	22	M16 x 65
17	Flat Washer	9012517	4	M16
18	Lock Washer	9012715	18	M16
19	Nut	9093439	22	M16 x 2.0
20	Rear Mounting Bracket	5099902	2	
21	Front Mounting Bracket	5099903	1	
22	Bolt	90931135	6	M20 x 46 x 75
23	Capacity Plate	80037	4	
24	Label	80048	1	
25	Calibration Chart		1	
26	Bolt	9004785	16	1/2 - 13 x 1 1/4
27	Lock Washer	9005313	16	1/2
28	Flat Washer	9012515	16	M12
29	Nut	9003905	16	1/2 - 13
30	Plain Caster	9007203	2	
31	Swivel Caster	9007202	2	
32	Bolt	9093106	10	M8 x 60
33	Lock Nut	9098506	10	M8 x 1.25
34	U Taper Washer	9043418	10	M16

Fig. No.	Name	Dwg. No.	Qty. per Assy.	Notes
0	Tester Frame Assy. cont.	50979	1	
35	Link Support	50614	2	
36	Hose Clamp	9009901	2	
37	Winch	9010701	1	
38	Serial Number Plate	80049	1	
39	Shackles	9010301	2	
40	Chain Particle Restraint Assy.	50788	1	
41	Bolt	9093349	2	M10 x 25
42	Bolt	9093124	12	M10 x 40
43	Lock Washer	9012712	12	M10
44	Nut	9093427	12	M10 x 1.5
45	Hook for Chain Particle Rest.	50790	1	
46	Nut	9093433	3	M12 x 1.75
47	Lock Washer	9012713	3	M12
48	Pulley Spacer	5099907	6	
49	Pulley Bushing	5099906	3	
50	Bolt	9093151	3	M12 x 70
51	Pulley Mount R. H.	5099904	1	
52	Pulley Mount L. H.	5099901	1	
53	Step Assembly	50767	1	
54	Washer	9005212	12	3/4
55	Shackle	9010303	1	

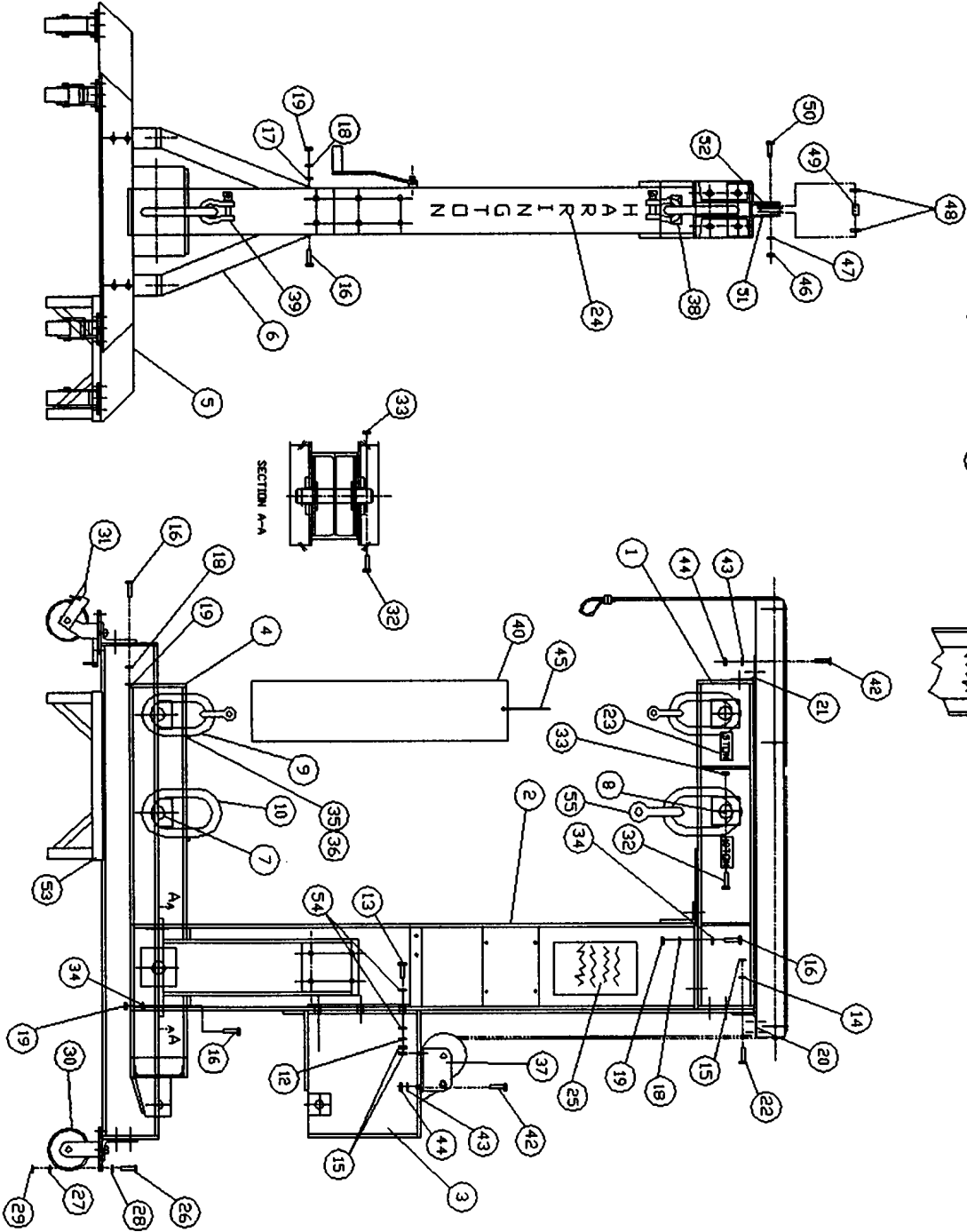
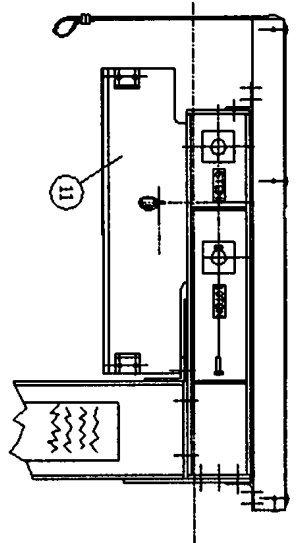

English/Metric Tester Frame Assembly
(50979)

4.7 Hydraulic Cylinder Assembly Static Option

Fig. No.	Name	Dwg. No.	Qty. per Assy.
12	Hydraulic Cylinder Assembly Static Option	9410201	1
22	U Bolt Assembly	9010401	2

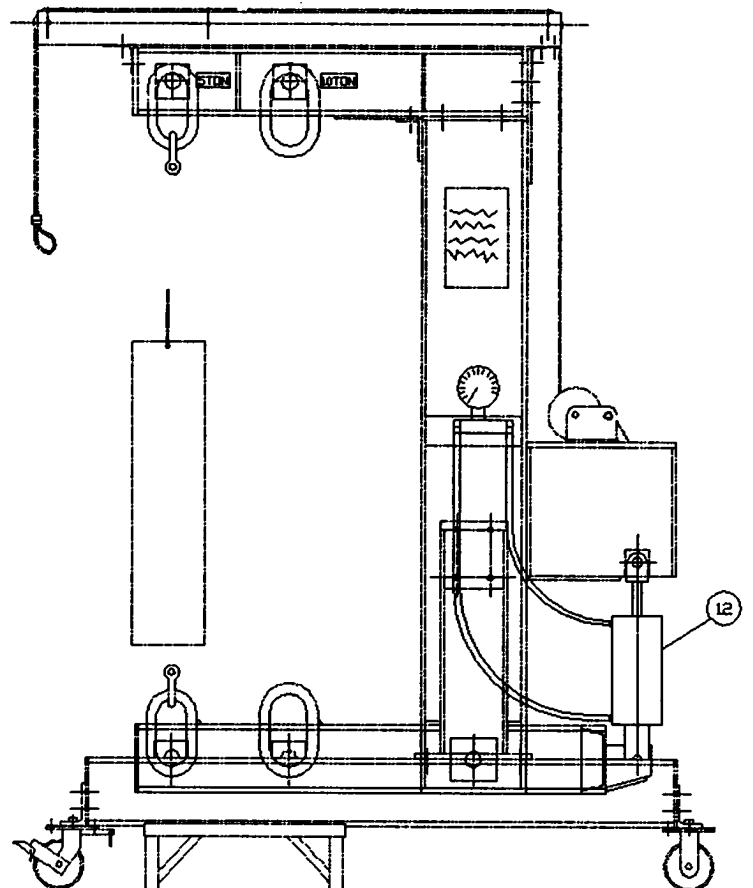
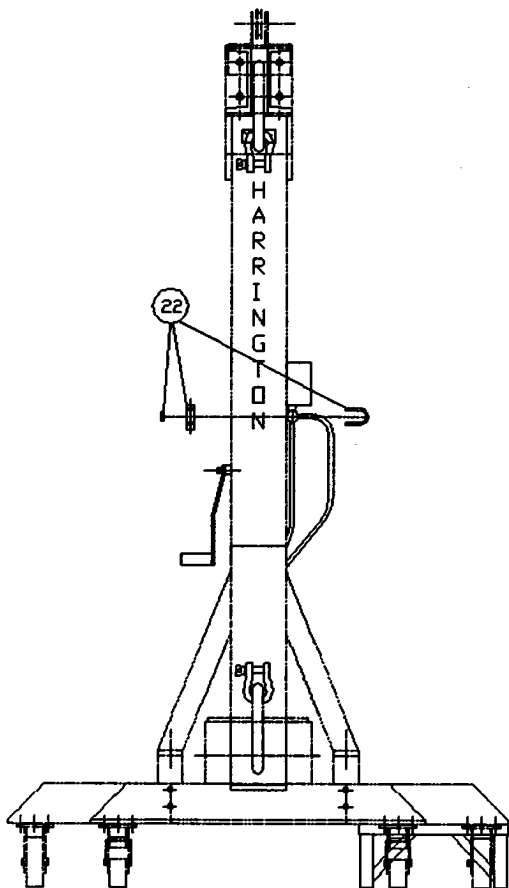

**English/Metric Tester - Static Option
(50979-1)**

4.8 English/Metric Tester Dynamic Option

Fig. No.	Name	Dwg. No.	Qty. per Assy.	Material
0	English/Metric Tester Dynamic Option	50924	1	
1	Electro-Hydraulic Assy. Cover	50923	1	
3	Front Support Assembly	5092102	1	
4	Electro-Hyd. Base Assy.	5092101	1	
5	Elect. Enclosure Sub Assembly	51624-6	1	
6	Bolt	9004706	10	1/4 - 20 - 1 1/4" long
7	Flat Washer	9005205	10	1/4"
8	Lock Nut	9004505	10	1/4 - 20
11	Bolt	9093369	2	M10 x 25
12	Lock Washer	9012712	4	M10
13	Nut	9093427	4	M10 x 1.5
14	Limit Switch Bracket	509207	1	
15	Bolt	9093328	10	M8 x 25
16	Lock Washer	9012711	18	M8
17	Socket Hd. Cap Screw		1	10 - 24 x 1" long
18	Bolt	9093145	4	M12 x 40
19	"U" Taper Washer	9043414	2	M12
20	Lock Washer	9012713	4	M12
21	Nut	9093433	4	M12 x 1.75
22	Nut	9093424	8	M8 x 1.25
23	Socket Hd. Cap Screw		1	10 - 24 x 2" long
25	Bolt	9093131	2	M10 x 75 x 26
27	Socket Hd. Cap Screw	9091276	8	M8 x 40
34	Nut	9003903	4	3/8 - 16
35	Eye Bolt	9010002	2	3/8 - 16 x 1 1/4 long
39	Limit Switch Assembly	-----	1	

Fig. No.	Name	Dwg. No.	Qty. per Assy.	Material
0	Dynamic Option Electric Hydraulic Subassembly	9010502	1	
9	4" Pressure Gauge	-----	1	
10	Pressure Setting Valve	-----	1	
24	Pressure Switch	-----	1	
28	Pump	-----	1	
29	Cylinder with Cushion	-----	1	
30	Accumulator	-----	1	
31	2" Pressure Gauge	-----	1	
32	Ball Valve	-----	1	
33	Filter	-----	1	
36	Accumulator Mtg. Brackets	-----	2	
37	Hoses	-----	----	
38	Fittings	-----	----	
40	Socket Head Cap Screw	9091272	2	M8 x 20
41	Lock Washer	9012711	2	M8

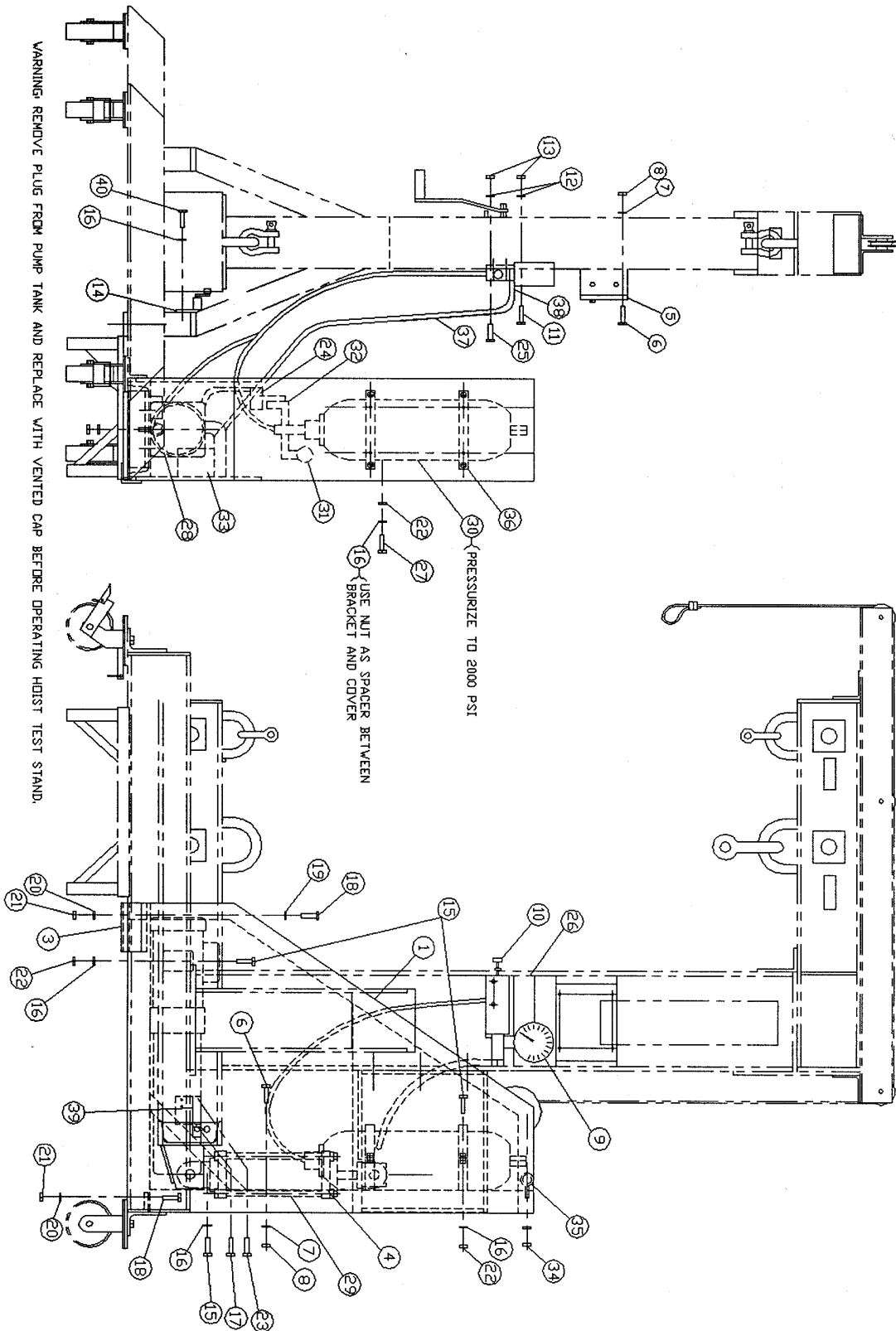

English/Metric Tester - Dynamic Option
(50924)

4.9 Electrical Components & Wiring Subassembly Dynamic Option

Name	Qty.	Harrington No.
Electrical Components & Wiring Subassembly Dynamic Option	1	51624-6
Junction Box	1	9006709
Panel	1	9006808
Push Button Operator	1	9009615
Early Close Contact Block	2	9009617
Alternate Action	1	9009621
Pilot Light Green	1	9009634
Legend Plate On/Off	1	9009635
Terminal Strip	1	MS518010
2 Push Button Cord Complete Set (new Kito cable)	1	ES1605D00310
1/2" Liquid Tight Connector	9	9008101
Socket 5P with 5 Leads	1	ES1614D015
Flat Head Machine Screw	4	E6FL558010
Flexible Conduit	20'	9008302
Cable 5C Complete Set	2	M7S1610010
1/2" Plastic Bushing	2	9008403
Contactor 110V	1	9006904
Limit Switch	1	9012201
Limit Lever	1	9012202
15 Amp Fuse	1	90062-25
Fuse Holder	1	90071-05
Philips Head Machine Screw (M5x12)	10	9798534
Nut (M5x0.8)	10	9093417
Spring Washer (M5)	10	9012708
S.O. Cord	30'	2 @7.5' & 1 @15'
4 Prong Plug Assembly	1	L1420P
S.O. Cord	7'	
1/2" "T" Outlet	2	9008701
1/2" "T" Outlet Cover	2	9008702
90° Liquid Tight Connector	2	9008901
Plug 5P	1	ES613003
Cable Holder 42 Assembly	1	E6F613003
Appleton Malleable Cover	1	9012101
5/10 AMP Fuse	1	90062-18

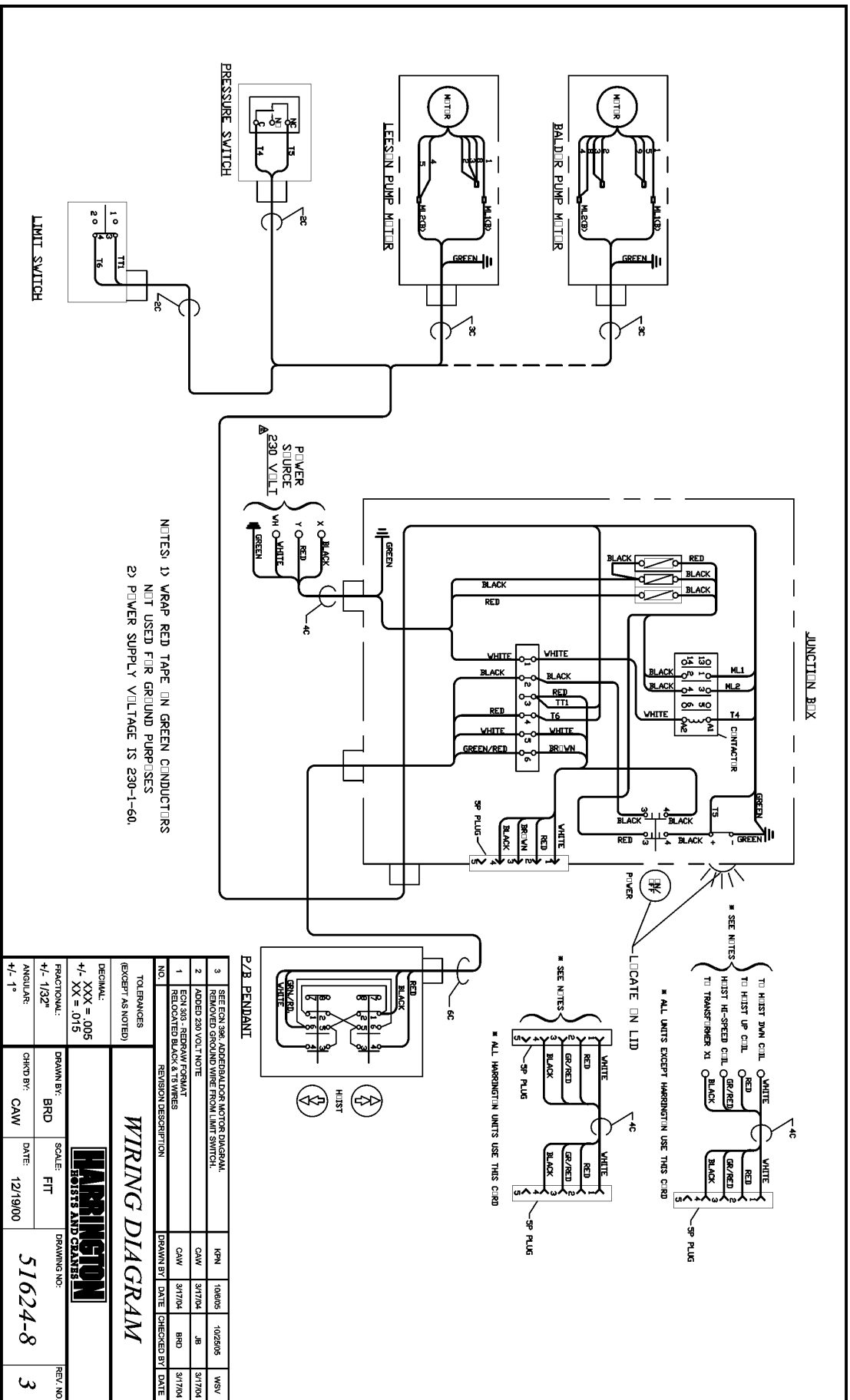

NO.	REVISION DESCRIPTION	DRAWN BY	DATE	CHECKED BY	DATE
1	RELOCATED BLACK & TS WIRES	CAW	3/17/04	BRD	3/17/04
2	ADDED 230 VOLT NOTE	CAW	3/17/04	JB	3/17/04
3	SEE ECH 386, ADDERBALLDOR MOTOR DIAGRAM, REMOVED GROUND WIRE FROM LIMIT SWITCH.	CAW	3/17/04	JB	3/17/04

TOLERANCES (EXCEPT AS NOTED)	
DECIMAL:	XXX = .005
FRACTIONAL:	+/- XX = .015
ANGULAR:	+/- 1/32"
ANGULAR:	+/- 1°

HARRINGTON RESISTS AND CRANES	DRAWING NO: 51624-8	REV. NO: 3
---	-------------------------------	----------------------

HARRINGTON HOISTS AND CRANES

www.harringtonhoists.com

Harrington Hoists, Inc.
401 West End Avenue
Manheim, PA 17545
Phone: 717-665-2000
Toll Free: 800-233-3010
Fax: 717-665-2861

Western Factory Warehouse
2341 Pomona Rincon Road #103
Corona, CA 92880
Phone: 909-279-7100
Toll Free: 800-317-7111
Fax: 909-279-7500

LTOM