

#### Purpose:

Use to connect ER or NER hoists to MR trolleys resulting in the hoist oriented parallel to the trolley beam. Note the hoist must be equipped with a Connection Yoke to utilize this suspender.

#### Specifications:

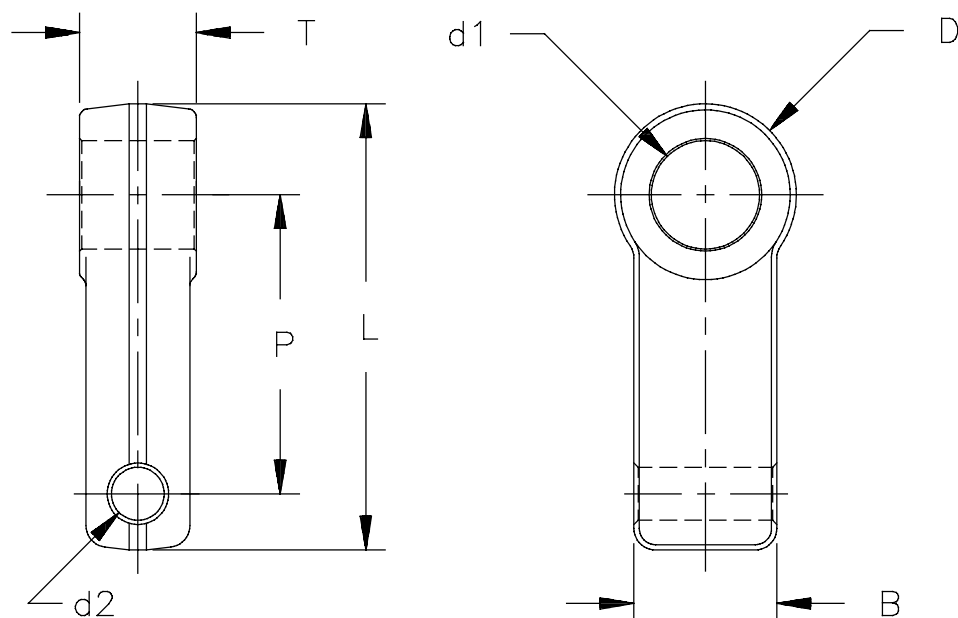

Part Number	Trolley Code	Capacities (Ton)	Dimensions - in (mm)						
			d1	D	d2	B	P	L	T
MR1DS9001	MR010L/S	1/8 to 1	1.223 (31.2)	1.89 (48)	0.480 (12.2)	1.30 (33)	2.72 (69)	4.17 (106)	1.08 (27.5)
MR1ES9001	MR020L/S	1 1/2 to 2	1.425 (36.2)	2.28 (58)	0.795 (20.2)	1.73 (44)	2.99 (76)	4.92 (125)	1.50 (38)
MR1FS9001	MR030L/S	2 1/2 to 3	1.701 (43.2)	2.76 (70)	0.795 (20.2)	1.73 (44)	3.35 (85)	5.61 (142.5)	1.54 (39)
MR1GS9001	MR050L/S	5	2.134 (54.2)	3.23 (82)	1.110 (28.2)	1.967 (50)	3.35 (85)	6.14 (156)	2.32 (59)