

Purpose

To provide dimension and specification information for Crane Components.

Attachments

<u>Pg</u>	<u>Type</u>	<u>Description</u>
2	Data Chart	Series 3 Top Running Motorized End Truck Specifications (Imperial / Metric)
3	Data Chart / Drawing	Series 3 Top Running Motorized End Truck Dimensions (Imperial)
4	Data Chart / Drawing	Series 3 Top Running Motorized End Truck Dimensions (Metric)
5	Data Chart / Drawing	Series 3 Top Running Geared End Truck Dimensions (Imperial)
6	Data Chart / Drawing	Series 3 Top Running Geared End Truck Dimensions (Metric)
7	Data Chart / Drawing	Series 3 Top Running Push End Truck Dimensions (Imperial)
8	Data Chart / Drawing	Series 3 Top Running Push End Truck Dimensions (Metric)
9	Data Chart / Drawing	Series 3 Underhung Motorized End Truck Specifications (Imperial)
10	Data Chart / Drawing	Series 3 Underhung Motorized End Truck Specifications (Metric)
11	Data Chart / Drawing	Series 3 Underhung Motorized End Truck Dimensions (Imperial)
12	Data Chart / Drawing	Series 3 Underhung Motorized End Truck Dimensions (Metric)
13	Data Chart / Drawing	Series 3 Underhung Geared End Truck Dimensions (Imperial)
14	Data Chart / Drawing	Series 3 Underhung Geared End Truck Dimensions (Metric)
15	Data Chart / Drawing	Series 3 Underhung Push End Truck Dimensions (Imperial)
16	Data Chart / Drawing	Series 3 Underhung Push End Truck Dimensions (Metric)
17	Data Chart / Drawing	Series 3 Max-E Top Running Motorized End Truck Specifications (Imperial)
18	Data Chart / Drawing	Series 3 Max-E Top Running Motorized End Truck Specifications (Metric)
19	Data Chart / Drawing	Series 3 Max-E Top Running Motorized End Truck Dimensions (Imperial)
20	Data Chart / Drawing	Series 3 Max-E Top Running Motorized End Truck Dimensions (Metric)
21	Data Chart / Drawing	Series 3 Max-E Top Running Geared End Truck Dimensions (Imperial)
22	Data Chart / Drawing	Series 3 Max-E Top Running Geared End Truck Dimensions (Metric)
23	Data Chart / Drawing	Series 3 Max-E Underhung Motorized End Truck Specifications (Imperial)
24	Data Chart / Drawing	Series 3 Max-E Underhung Motorized End Truck Specifications (Metric)
25	Data Chart / Drawing	Series 3 Max-E Underhung Motorized End Truck Dimensions (Imperial)
26	Data Chart / Drawing	Series 3 Max-E Underhung Motorized End Truck Dimensions (Metric)
27	Data Chart / Drawing	Series 3 Max-E Underhung Geared End Truck Dimensions (Imperial)
28	Data Chart / Drawing	Series 3 Max-E Underhung Geared End Truck Dimensions (Metric)
29	Data Chart / Drawing	HPC200A Top Running End Truck / Underhung End Truck (Imperial)
30	Data Chart / Drawing	HPC200A Top Running End Truck / Underhung End Truck (Metric)
31	Data Chart / Drawing	HPC300 Top Running End Truck / Underhung End Truck (Imperial)
32	Data Chart / Drawing	HPC300 Top Running End Truck / Underhung End Truck (Metric)

See EDOC0192 for HPC500.

Imperial

Series 3 Top Running Motorized End Truck										
End Truck Product Code	Speed Codes L and S			Speed Code H			Speed Code D			End Truck Weight (lbs/pair)
	One Motor Per End Truck 3 Phase 60 Hz			One Motor Per End Truck 3 Phase 60 Hz			One Motor Per End Truck 3 Phase 60 Hz			
	Output (Hp)	Rated Current (amps ea.)		Output (Hp)	Rated Current (amps ea.)		Output (Hp)	Rated Current (amps ea.)		
		@230V	@460V		@230V	@460V		@230V	@460V	
TML/S/H/D-3-0135	0.33	1.6	1.0	0.5	2.1	1.3	0.33/0.08	1.6/1.1	0.9/0.8	325
TML/S/H/D-3-0160										422
TML/S/H/D-3-0335										421
TML/S/H/D-3-0360										538
TML/S/H/D-3-0535										512
TML/S/H/D-3-0560	0.5	2.1	1.3	1.0	3.3	2.0	0.5/0.13	2.0/1.5	1.2/0.9	739
TML/S/H/D-3-1035	1.0	3.3	2.0	2.0	5.8	3.1	1.0/0.25	3.7/2.1	2.3/1.4	883
TML/S/H/D-3-1060										1063

Speed Code

L - Designates 40 ft/min
 S - Designates 80 ft/min
 H - Designates 120 ft/min
 D - Designates dual speed 80/20 ft/min

Product code derivation - example: TML-3-0135

T - Top Running
 M - Motorized
 L - Speed of 40 ft/min
 3 - Series number
 01 - Max. Capacity - 1 Ton
 35 - Maximum span - 35 feet

Metric

Series 3 Top Running Motorized End Truck										
End Truck Product Code	Speed Codes L and S			Speed Code H			Speed Code D			End Truck Weight (kg/pair)
	One Motor Per End Truck 3 Phase 60 Hz			One Motor Per End Truck 3 Phase 60 Hz			One Motor Per End Truck 3 Phase 60 Hz			
	Output (kW)	Rated Current (amps ea.)		Output (kW)	Rated Current (amps ea.)		Output (kW)	Rated Current (amps ea.)		
		@230V	@460V		@230V	@460V		@230V	@460V	
TML/S/H/D-3-0135	0.25	1.6	1.0	0.4	2.1	1.3	0.25/0.063	1.6/1.1	0.9/0.8	147.4
TML/S/H/D-3-0160										191.4
TML/S/H/D-3-0335										191.0
TML/S/H/D-3-0360										244.0
TML/S/H/D-3-0535										232.2
TML/S/H/D-3-0560	0.4	2.1	1.3	0.75	3.3	2.0	0.4/0.1	2.0/1.5	1.2/0.9	335.2
TML/S/H/D-3-1035	0.75	3.3	2.0	1.5	5.8	3.1	0.75/0.19	3.7/2.1	2.3/1.4	400.5
TML/S/H/D-3-1060										482.2

Speed Code

L - Designates 12 m/min
 S - Designates 24 m/min
 H - Designates 36 m/min
 D - Designates dual speed 24/6 m/min

Product code derivation - example: TML-3-0135

T - Top Running
 M - Motorized
 L - Speed of 12 m/min
 3 - Series number
 01 - Max. Capacity - 1 Ton
 35 - Maximum span - 35 feet (10.7 meters)

Imperial

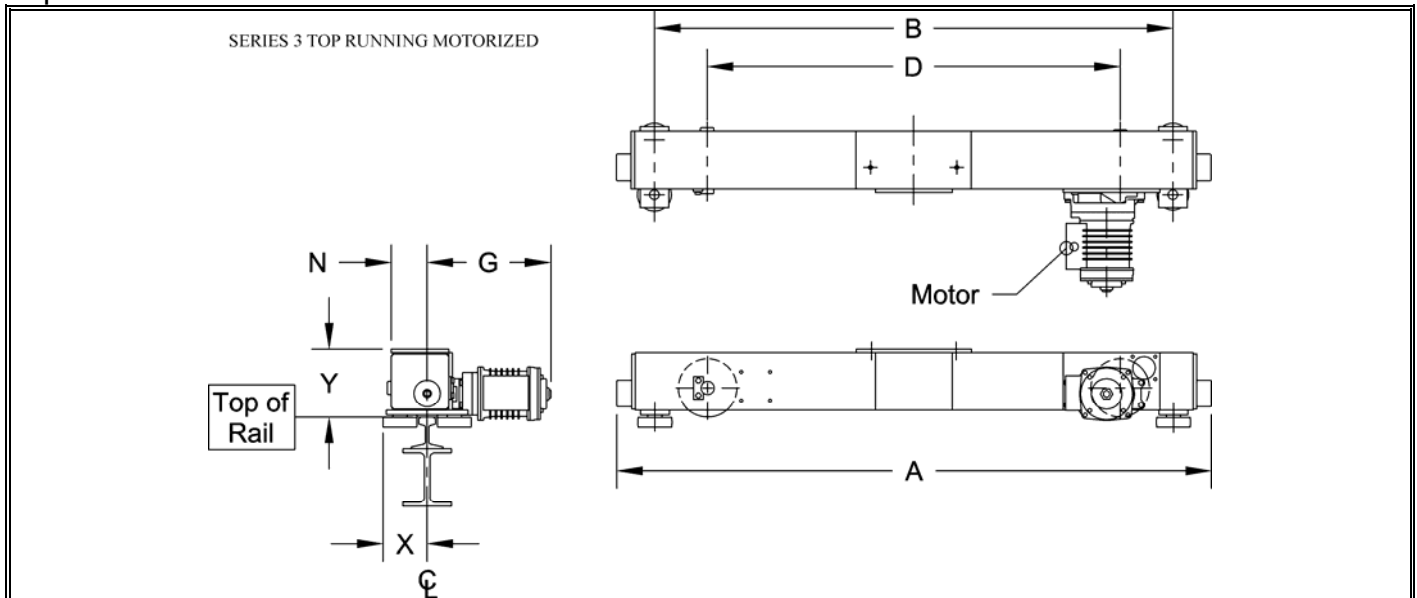

Cap. (Tons)	Max. Span (ft)	End Truck Product Code	Wheel Diameter (in)	Sug. Min. Runway Rail (ACSE#)	A Overall Length (in)	B Roller Base (in)	D Wheel Base (in)	N Runway Ctr Line to Outer Edge of ET Tube (in)	X* Width Beyond Span (in)	Y Top of Rail to Top of End Truck (in)	G Motor (in)		
1	35	TML/S/H/D-3-0135	3.74	30	61	53	43	2.1	4.6	7.1	12.7 (L/S) 13.1 (H) 14.0 (D)		
	60	TML/S/H/D-3-0160			98	90	80						
3	35	TML/S/H/D-3-0335	6.10		62	54	43	3.8				9.2	13.0 (L/S) 13.4 (H) 14.3 (D)
	60	TML/S/H/D-3-0360			99	91	80						
5	35	TML/S/H/D-3-0535	8.27	40	62	54	43	4.7	9.3	15.0 (L/S/D) 15.4 (H)			
	60	TML/S/H/D-3-0560			99	90	74				3.5		
10	35	TML/S/H/D-3-1035	9.84	60	63	53	37	5.3	6.3	11.3	17.4 (L/S/D) 18.7 (H)		
	60	TML/S/H/D-3-1060			100	90	74						

* Based on suggested minimum runway rail.

Metric

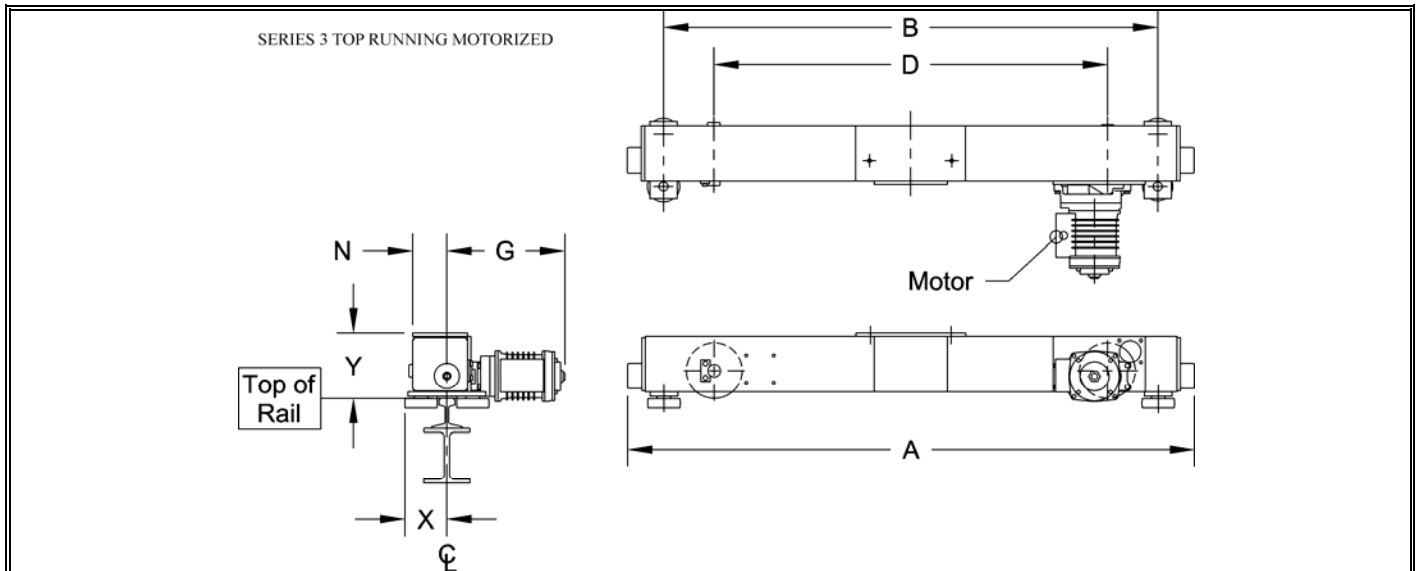

Cap. (Tons)	Max. Span (m)	End Truck Product Code	Wheel Diameter (mm)	Sug. Min. Runway Rail (ACSE#)	A Overall Length (mm)	B Roller Base (mm)	D Wheel Base (mm)	N Runway Ctr Line to Outer Edge of ET Tube (mm)	X* Width Beyond Span (mm)	Y Top of Rail to Top of End Truck (mm)	G Motor (mm)
1	10.7	TML/S/H/D-3-0135	95	30	1549	1346	1092	53	117	180	323 (L/S) 333 (H) 356 (D)
	18.3	TML/S/H/D-3-0160			2489	2286	2032				
3	10.7	TML/S/H/D-3-0335	155		1575	1372	1092	97			
	18.3	TML/S/H/D-3-0360			2515	2311	2032				
5	10.7	TML/S/H/D-3-0535	210	40	1575	1372	1092	119	234		
	18.3	TML/S/H/D-3-0560			2515	2286	1880		89	236	381 (L/S/D) 391 (H)
10	10.7	TML/S/H/D-3-1035	250	60	1600	1346	940	135	160	287	442 (L/S/D) 475 (H)
	18.3	TML/S/H/D-3-1060			2540	2286	1880				

* Based on suggested minimum runway rail.

Imperial

SERIES 3 TOP RUNNING GEARED

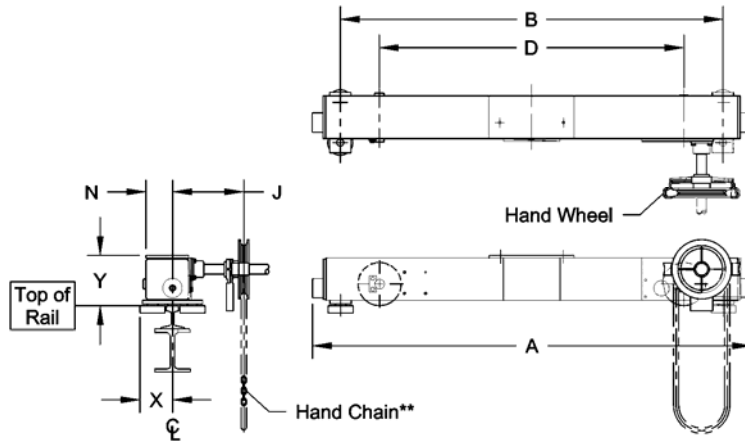

Cap. (Tons)	Max. Span (ft)	End Truck Product Code	Wheel Diameter (in)	Sug. Min. Runway Rail (ACSE#)	A Overall Length (in)	B Roller Base (in)	D Wheel Base (in)	J Hand Wheel Offset (in)	N Runway Ctr Line to Outer Edge of ET Tube (in)	X* Width Beyond Span (in)	Y Top of Rail to Top of End Truck (in)	End Truck Weight (lbs/pr)
1	35	TG-3-0135	3.74	30	61	53	43	9.7	2.1	4.6	7.1	264
	50	TG-3-0150			98	90	80					360
3	35	TG-3-0335	6.10		62	54	43	10.0	3.8			359
	50	TG-3-0350			99	91	80					477
5	35	TG-3-0535		8.27	40	62	54			43	10.3	3.5
	50	TG-3-0550	99			90	74	9.3	703			

* Based on suggested minimum runway rail.

**Standard hand chain drop is 8 ft. from top of runway rail

Metric

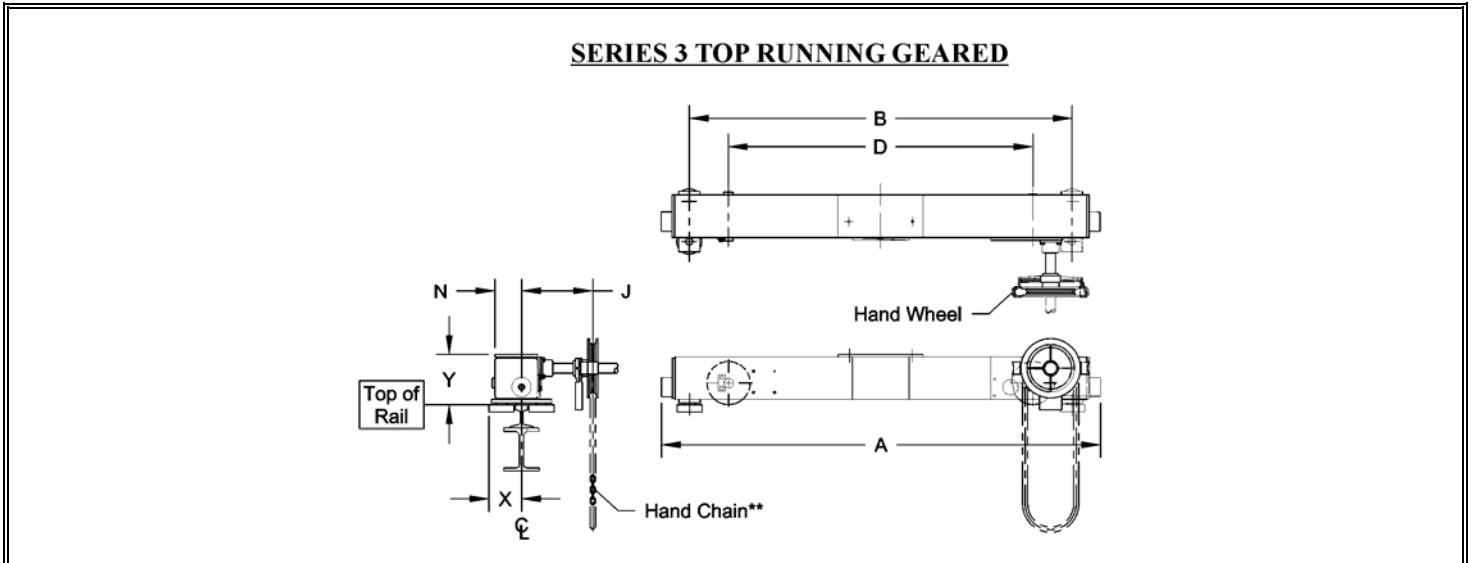

Cap. (Tons)	Max. Span (m)	End Truck Product Code	Wheel Diameter (mm)	Sug. Min. Runway Rail (ACSE#)	A Overall Length (mm)	B Roller Base (mm)	D Wheel Base (mm)	J Hand Wheel Offset (mm)	N Runway Ctr Line to Outer Edge of ET Tube (mm)	X* Width Beyond Span (mm)	Y Top of Rail to Top of End Truck (mm)	End Truck Weight (kg/pr)
1	10.7	TG-3-0135	95	30	1549	1346	1092	246	53	117	180	119.8
	15.2	TG-3-0150			2489	2286	2032					163.3
3	10.7	TG-3-0335	155		1575	1372	1092	254	97			162.8
	15.2	TG-3-0350			2515	2311	2032					216.4
5	10.7	TG-3-0535		210	40	1575	1372			1092	119	234
	15.2	TG-3-0550	2515			2286	1880	262	89	236		318.9

* Based on suggested minimum runway rail.

**Standard hand chain drop is 8 ft. (2.4 meters) from top of runway rail

Imperial

SERIES 3 TOP RUNNING PUSH

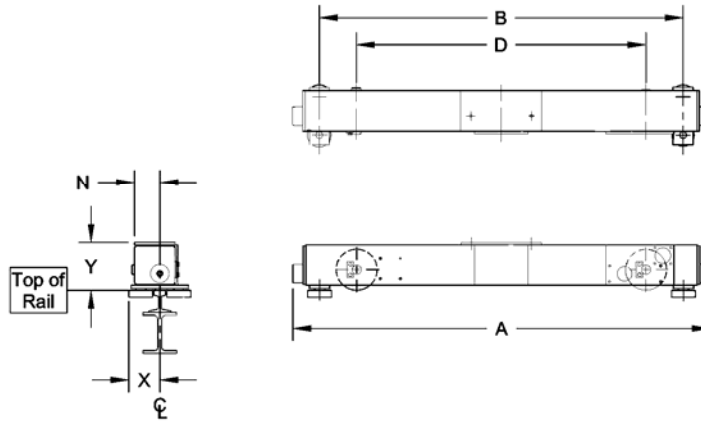

Cap. (Tons)	Max. Span (ft)	End Truck Product Code	Wheel Diameter (in)	Sug. Min. Runway Rail (ACSE#)	A Overall Length (in)	B Roller Base (in)	D Wheel Base (in)	N Runway Ctr Line to Outer Edge of ET Tube (in)	X* Width Beyond Span (in)	Y Top of Rail to Top of End Truck (in)	End Truck Weight (lbs/pr)		
1	35	TP-3-0135	3.74	30	61	53	43	2.1	4.6	7.1	242		
	45	TP-3-0145			98	90					338		
2	45	TP-3-0245	6.10		99	91	80	3.8			4.7	9.2	454
3	35	TP-3-0335			62	54	43						337
5	35	TP-3-0535		40							420		

* Based on suggested minimum runway rail.

Metric

SERIES 3 TOP RUNNING PUSH

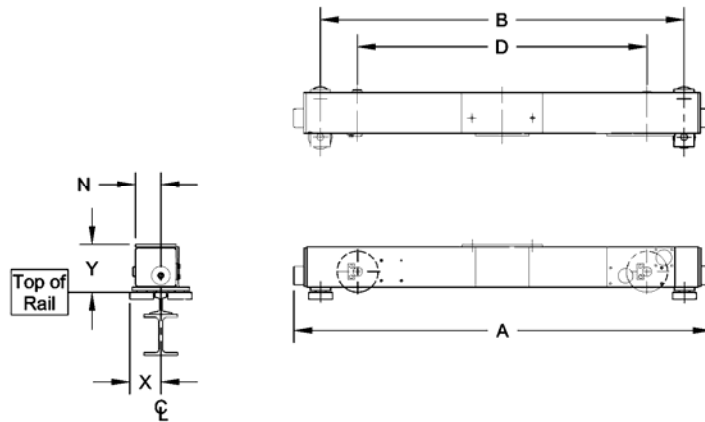

Cap. (Tons)	Max. Span (m)	End Truck Product Code	Wheel Diameter (mm)	Sug. Min. Runway Rail (ACSE#)	A Overall Length (mm)	B Roller Base (mm)	D Wheel Base (mm)	N Runway Ctr Line to Outer Edge of ET Tube (mm)	X* Width Beyond Span (mm)	Y Top of Rail to Top of End Truck (mm)	End Truck Weight (kg/pr)
1	10.7	TP-3-0135	95	30	1549	1346	1092	53	117	180	109.8
	13.7	TP-3-0145			2489	2286	2032				153.3
2	13.7	TP-3-0245	155	30	2515	2311	2032	97	117	180	205.9
3	10.7	TP-3-0335			1575	1372	1092				152.9
5	10.7	TP-3-0535			40	1575	1372				1092

* Based on suggested minimum runway rail.

Imperial

SERIES 3 UNDERHUNG MOTORIZED

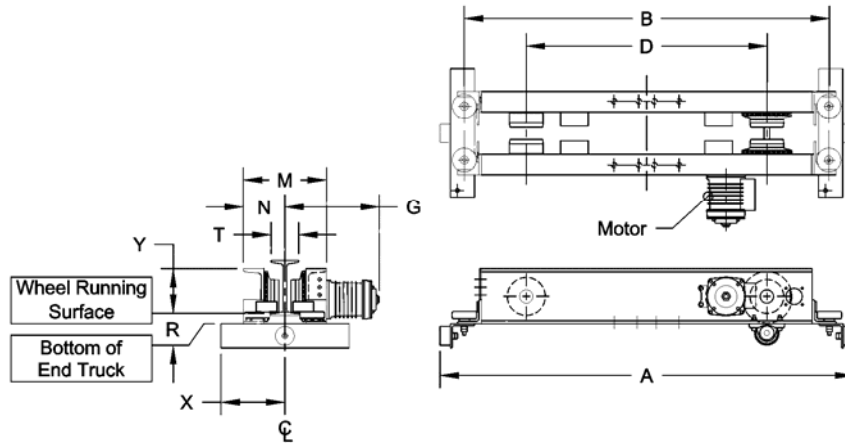

End Truck Product Code	Speed Codes L and S			Speed Code H			Speed Code D			End Truck Weight (lbs/pair)
	One Motor Per End Truck 3 Phase 60 Hz			One Motor Per End Truck 3 Phase 60 Hz			One Motor Per End Truck 3 Phase 60 Hz			
	Output (Hp)	Rated Current (amps ea.)		Output (Hp)	Rated Current (amps ea.)		Output (Hp)	Rated Current (amps ea.)		
		@230V	@460V		@230V	@460V		@230V	@460V	
UML/S/H/D-3-0235	0.33	1.6	1.0	0.5	2.1	1.3	0.33/0.1	1.6/1.1	0.9/0.8	522
UML/S/H/D-3-0250										659
UML/S/H/D-3-0335										543
UML/S/H/D-3-0350	0.5	2.1	1.3	1.0	3.3	2.0	0.5/0.13	2.0/1.5	1.2/0.9	680
UML/S/H/D-3-0535										638
UML/S/H/D-3-0550										795

Speed Code

L - Designates 40 ft/min

S - Designates 80 ft/min

H - Designates 120 ft/min

D - Designates dual speed 80/20 ft/min

Product code derivation - example: UML-3-0235

U - Underhung

M - Motorized

L - Speed of 40 ft/min

3 - Series number

02 - Max. Capacity - 2 Ton

35 - Maximum span - 35 feet

Metric

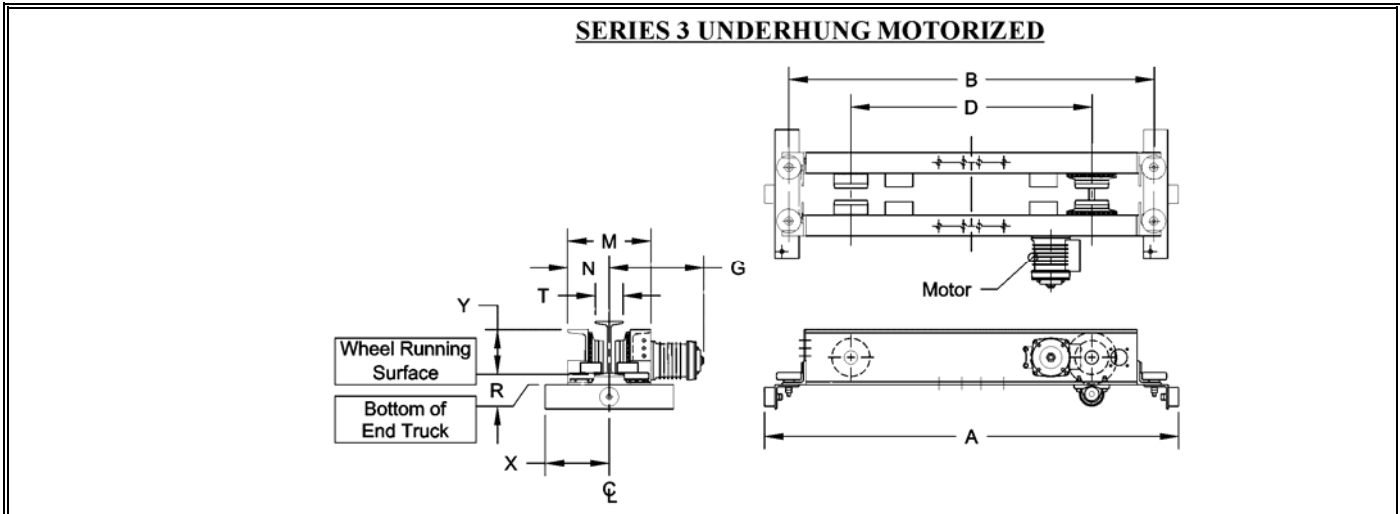

End Truck Product Code	Speed Codes L and S			Speed Code H			Speed Code D			End Truck Weight (kg/pair)
	One Motor Per End Truck 3 Phase 60 Hz			One Motor Per End Truck 3 Phase 60 Hz			One Motor Per End Truck 3 Phase 60 Hz			
	Output (kW)	Rated Current (amps ea.)		Output (kW)	Rated Current (amps ea.)		Output (kW)	Rated Current (amps ea.)		
		@230V	@460V		@230V	@460V		@230V	@460V	
UML/S/H/D-3-0235	0.25	1.6	1.0	0.4	2.1	1.3	0.25/0.063	1.6/1.1	0.9/0.8	236.8
UML/S/H/D-3-0250										299.0
UML/S/H/D-3-0335										246.3
UML/S/H/D-3-0350										308.4
UML/S/H/D-3-0535	0.4	2.1	1.3	0.75	3.3	2.0	0.4/0.01	2.0/1.5	1.2/0.9	289.4
UML/S/H/D-3-0550										360.6

Speed Code

- L - Designates 12 m/min
- S - Designates 24 m/min
- H - Designates 36 m/min
- D - Designates dual speed 24/6 m/min

Product code derivation - example: UML-3-0235

- U - Underhung
- M - Motorized
- L - Speed of 12 m/min
- 3 - Series number
- 02 - Max. Capacity - 2 Ton
- 35 - Maximum span-35ft (10.7 meters)

Imperial

SERIES 3 UNDERHUNG MOTORIZED

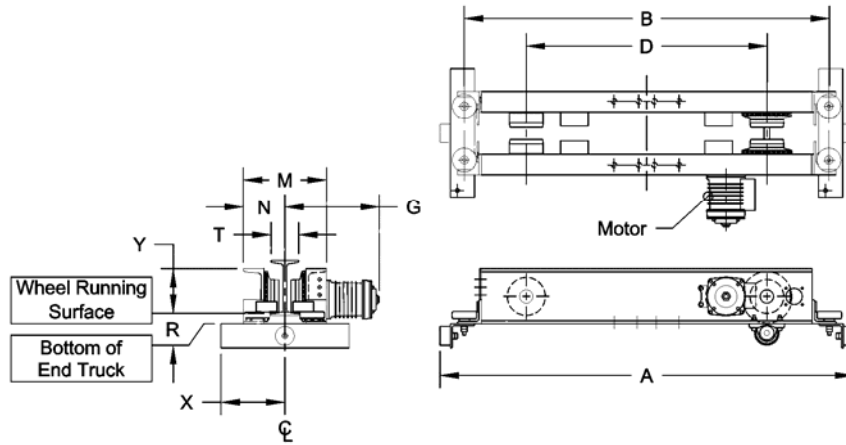

Cap. (Tons)	Max. Span (ft)	End Truck Product Code	Wheel Diameter (in)	T Flange Range Std. (in)	A Overall Length (in)	B Roller Base (in)	D Wheel Base (in)	M End Truck Frame Width (in)	N Runway Ctr Line to Outer Edge of ET (in)	R Wheel Running Surf. To Bottom of Truck (in)	X* Width Beyond Span (in)	Y Wheel Running Surface to Upper Most Part of ET (in)	G Motor (in)
2	35	UML/S/H/D-3-0235	4.33	3 - 6	60	53	39	T+8.1	M/2	1.5	11.3- T/2	6.5	T/2 + 11.9 (L/S) T/2 + 12.3 (H) T/2 + 13.3 (D)
	50	UML/S/H/D-3-0250			82	75	61						
3	35	UML/S/H/D-3-0335	4.92	3 - 6	60	53	35	T+8.2	M/2	1.5	11.3- T/2	6.5	T/2 + 11.9 (L/S) T/2 + 12.3 (H) T/2 + 13.3 (D)
	50	UML/S/H/D-3-0350			82	75	57						
5	35	UML/S/H/D-3-0535	5.51	4 - 6	60	53	33	T+9.8	M/2	1.6	11.3- T/2	6.8	T/2+13.7 (L/S/D) T/2 + 14.2(H)
	50	UML/S/H/D-3-0550			82	75	55						

* These formulas for Width Beyond Span do not apply for flanges greater than 6 inches. For flanges greater than 6 inches (152mm), consult factory.

Metric

SERIES 3 UNDERHUNG MOTORIZED

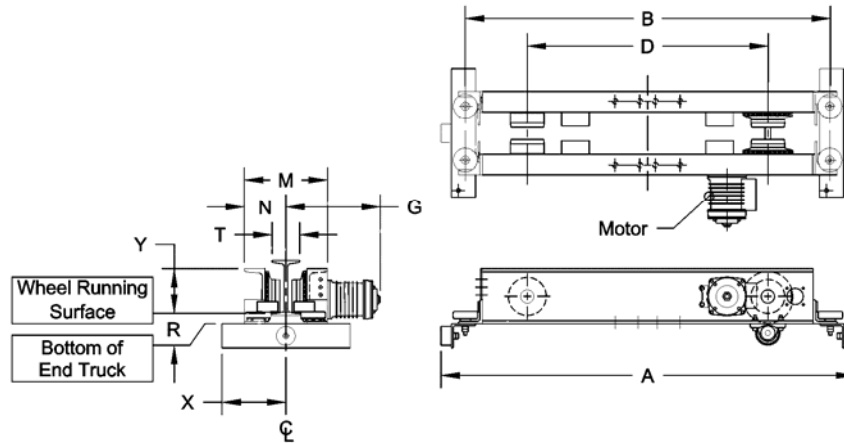

Cap. (Tons)	Max. Span (m)	End Truck Product Code	Wheel Diameter (mm)	T Flange Range Std. (mm)	A Overall Length (mm)	B Roller Base (mm)	D Wheel Base (mm)	M End Truck Frame Width (mm)	N Runway Ctr Line to Outer Edge of ET (mm)	R Wheel Running Surf. To Bottom of Truck (mm)	X* Width Beyond Span (mm)	Y Wheel Running Surface to Upper Most Part of ET (mm)	G Motor (mm)
2	10.7	UML/S/H/D-3-0235	110	76 - 152	1524	1346	991	T+206		38		165	T/2 + 302 (L/S) T/2 + 312 (H) T/2 + 338 (D)
	15.2	UML/S/H/D-3-0250			2083	1905	1549						
3	10.7	UML/S/H/D-3-0335	125	76 - 152	1524	1346	889	T+208	M/2		287 - T/2		
	15.2	UML/S/H/D-3-0350			2083	1905	1448						
5	10.7	UML/S/H/D-3-0535	140	102 - 152	1524	1346	838	T+249		41		173	T/2+348 (L/S/D) T/2 + 361 (H)
	15.2	UML/S/H/D-3-0550			2083	1905	1397						

* These formulas for Width Beyond Span do not apply for flanges greater than 6 inches. For flanges greater than 6 inches (152mm), consult factory.

Imperial

SERIES 3 UNDERHUNG GEARED

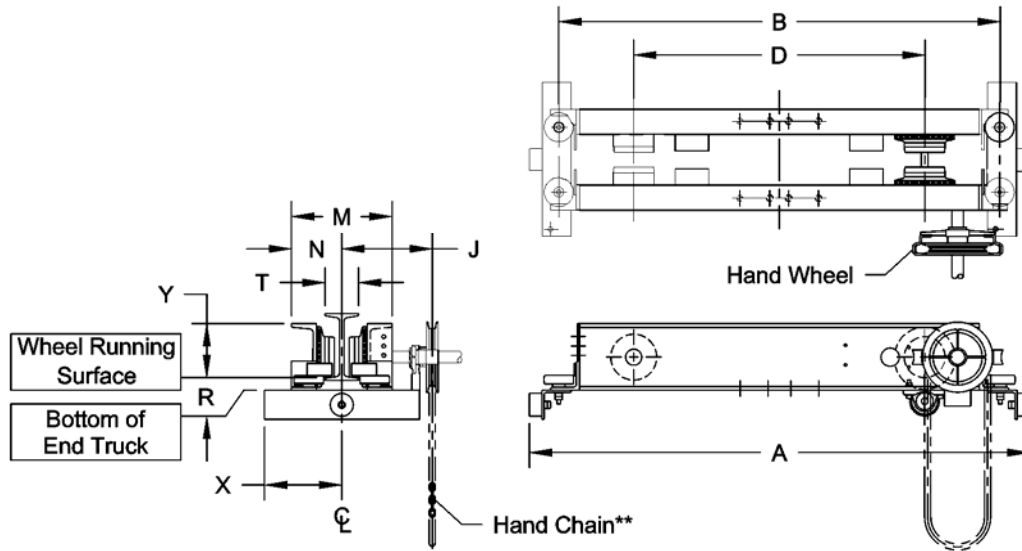

Cap. (Tons)	Max. Span (ft)	End Truck Product Code	Wheel Diameter (in)	T Flange Range Std. (in)	A Overall Length (in)	B Roller Base (in)	D Wheel Base (in)	J Hand Wheel Offset (in)	M End Truck Frame Width (in)	N Runway Ctr Line to Outer Edge of ET (in)	R Wheel Running Surf. To Bottom of Truck (in)	X* Width Beyond Span (in)	Y Wheel Running Surface to Upper Most Part of ET (in)	End Truck Weight (lbs/pr)
2	35	UG-3-0235	4.33	3 - 6	60	53	39	T/2+9.0	T+8.1	M/2	1.5	11.3 - T/2	6.5	503
	45	UG-3-0245			82	75	61							640
3	35	UG-3-0335	4.92		60	53	35	T/2+8.9	T+8.2				6.7	529
	45	UG-3-0345			82	75	57							666
5	35	UG-3-0535	5.51	4 - 6	60	53	33	T/2+9.0	T+9.8	6.8	1.6	6.8	611	
	45	UG-3-0545			82	75	55						768	

* These formulas for Width Beyond Span do not apply for flanges greater than 6 inches. For flanges greater than 6 inches, consult factory.

** Standard hand chain drop is 8 ft. from bottom of runway beam

Metric

SERIES 3 UNDERHUNG GEARED

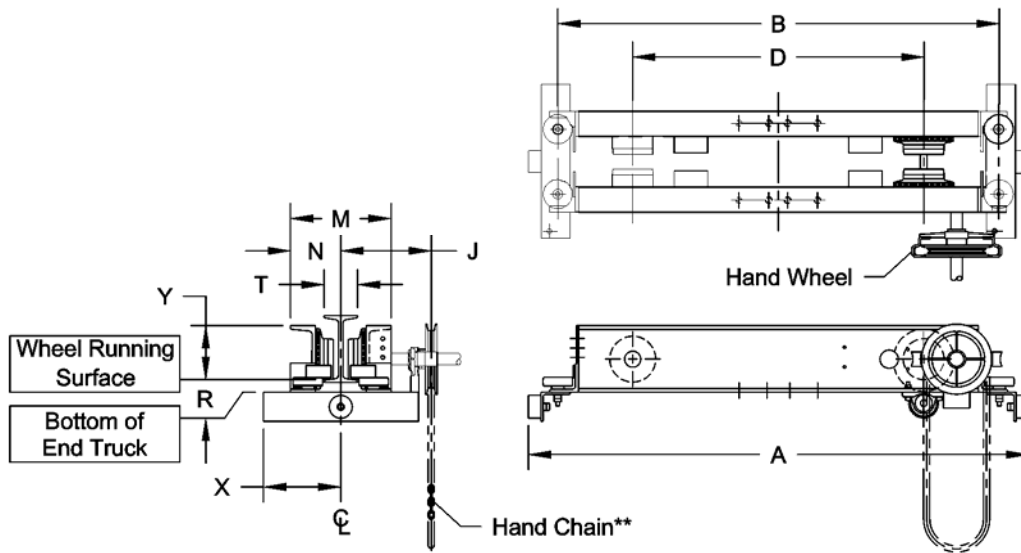

Cap. (Tons)	Max. Span (m)	End Truck Product Code	Wheel Diameter (mm)	T Flange Range Std. (mm)	A Overall Length (mm)	B Roller Base (mm)	D Wheel Base (mm)	J Hand Wheel Offset (mm)	M End Truck Frame Width (mm)	N Runway Ctr Line to Outer Edge of ET (mm)	R Wheel Running Surf. To Bottom of Truck (mm)	X* Width Beyond Span (mm)	Y Wheel Running Surface to Upper Most Part of ET (mm)	End Truck Weight (kg/pr)
2	10.7	UG-3-0235	110	76-152	1524	1346	991	T/2+229	T+206	M/2	38	287 - T/2	165	228.2
	13.7	UG-3-0245			2083	1905	1549							290.3
3	10.7	UG-3-0335	125	76-152	1524	1346	889	T/2+226	T+208	M/2	38	287 - T/2	170	240.0
	13.7	UG-3-0345			2083	1905	1448							302.1
5	10.7	UG-3-0535	140	102-152	1524	1346	838	T/2+229	T+249	M/2	41	287 - T/2	173	277.2
	13.7	UG-3-0545			2083	1905	1397							348.4

* These formulas for Width Beyond Span do not apply for flanges greater than 6" (152mm). For flanges greater than 6" (152mm), consult factory.

** Standard hand chain drop is 8ft. (2.4m) from bottom of runway beam

Imperial

SERIES 3 UNDERHUNG PUSH

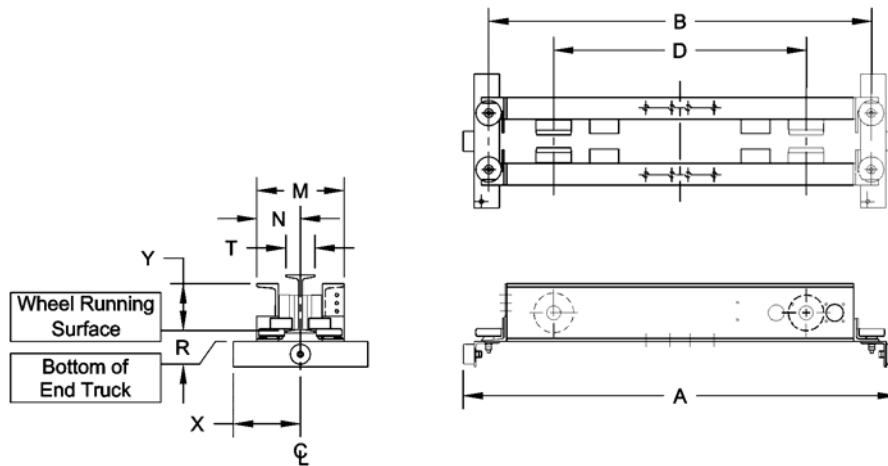

Cap. (Tons)	Max. Span (ft)	End Truck Product Code	Wheel Diameter (in)	T Flange Range Std. (in)	A Overall Length (in)	B Roller Base (in)	D Wheel Base (in)	M End Truck Frame Width (in)	N Runway Ctr Line to Outer Edge of ET (in)	R Wheel Running Surf. To Bottom of Truck (in)	X* Width Beyond Span (in)	Y Wheel Running Surface to Upper Most Part of ET (in)	End Truck Weight (lbs/pr)
2	35	UP-3-0235	4.33	3 - 6	60	53	39	T+8.1	M/2	1.5	11.3-T/2	6.5	448
	45	UP-3-0245			82	75	61	585					
3	35	UP-3-0335	4.92		60	53	35	T + 8.2					472
5	35	UP-3-0535	5.51	4 - 6	60	53	33	T+9.8		1.6			6.4

* These formulas for Width Beyond span do not apply for flanges greater than 6 inches. For flanges greater than 6 inches, consult factory.

Metric

SERIES 3 UNDERHUNG PUSH

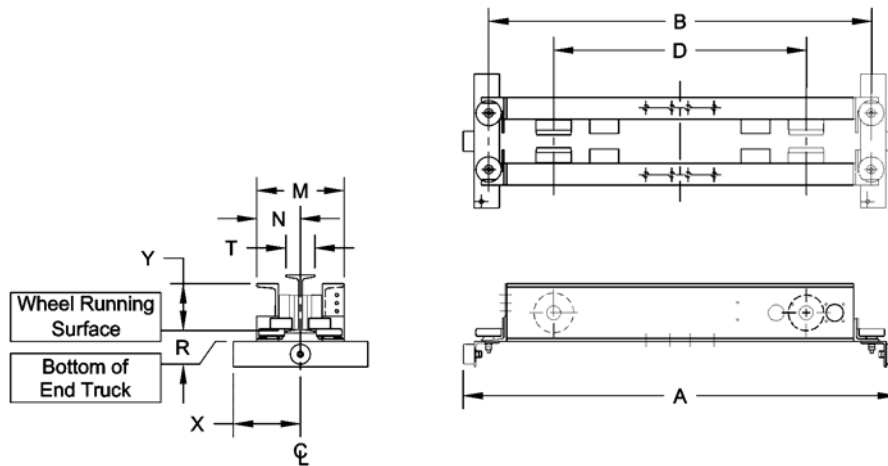

Cap. (Tons)	Max. Span (m)	End Truck Product Code	Wheel Diameter (mm)	T Flange Range Std. (mm)	A Overall Length (mm)	B Roller Base (mm)	D Wheel Base (mm)	M End Truck Frame Width (mm)	N Runway Ctr Line to Outer Edge of ET (mm)	R Wheel Running Surf. To Bottom of Truck (mm)	X* Width Beyond Span (mm)	Y Wheel Running Surface to Upper Most Part of ET (mm)	End Truck Weight (kg/pr)
2	10.7	UP-3-0235	110	76-152	1524	1346	991	T+206	M/2	38	287-T/2	165	203.2
	13.7	UP-3-0245			2083	1905	1549						265.4
3	10.7	UP-3-0335	125		1524	1346	889	T+208					214.1
5	10.7	UP-3-0535	140	102-152	1524	1346	838	T+249					41

* These formulas for Width Beyond span do not apply for flanges greater than 6" (152mm). For flanges greater than 6" (152mm), consult factory.

Imperial

SERIES 3 MAX-E-LIFT TOP RUNNING MOTORIZED

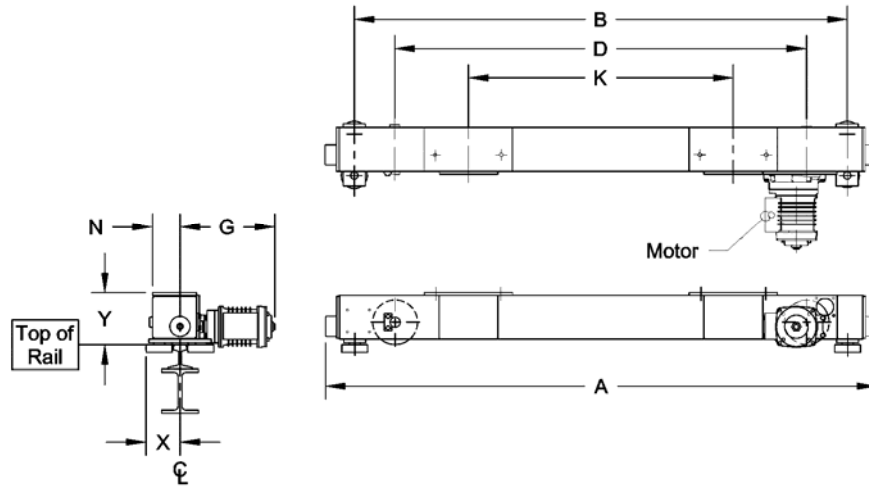

End Truck Product Code	Speed Codes L and S			Speed Code H			Speed Code D			End Truck Weight (lbs/pair)
	One Motor Per End Truck 3 Phase 60 Hz			One Motor Per End Truck 3 Phase 60 Hz			One Motor Per End Truck 3 Phase 60 Hz			
	Output (Hp)	Rated Current (amps ea.)		Output (Hp)	Rated Current (amps ea.)		Output (Hp)	Rated Current (amps ea.)		
@230V		@460V	@230V		@460V	@230V		@460V		
MTML/S/H/D-3-0135	0.33	1.6	1.0	0.5	2.1	1.3	0.33/0.10	1.6/1.1	0.9/0.8	340
MTML/S/H/D-3-0160										441
MTML/S/H/D-3-0335										526
MTML/S/H/D-3-0360										647
MTML/S/H/D-3-0535	0.5	2.1	1.3	1.0	3.3	2.0	0.5/0.13	2.0/1.5	1.2/0.9	648
MTML/S/H/D-3-0560										818
MTML/S/H/D-3-1035										1,105
MTML/S/H/D-3-1060	1,202									

Speed Code

- L - Designates 40 ft/min
- S - Designates 80 ft/min
- H - Designates 120 ft/min
- D - Designates dual speed 80/20 ft/min

Product code derivation - example: MTML-3-0135

- 1st M - Max-E-Lift Style
- T - Top Running
- 2nd M - Motorized
- L - Speed of 40 ft/min
- 3 - Series number
- 01 - Max. Capacity - 1 Ton
- 35 - Maximum span - 35 feet

Metric

SERIES 3 MAX-E-LIFT TOP RUNNING MOTORIZED

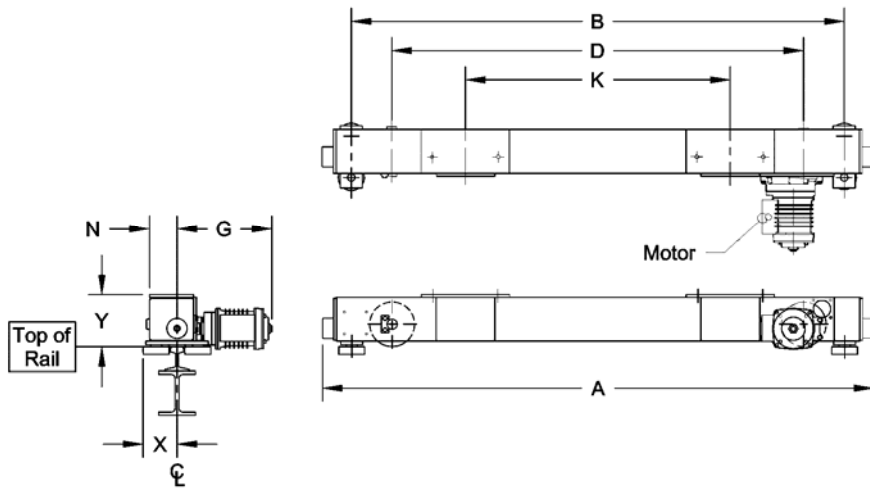

End Truck Product Code	Speed Codes L and S			Speed Code H			Speed Code D			End Truck Weight (kg/pair)
	One Motor Per End Truck 3 Phase 60 Hz			One Motor Per End Truck 3 Phase 60 Hz			One Motor Per End Truck 3 Phase 60 Hz			
	Output (kW)	Rated Current (amps ea.)		Output (kW)	Rated Current (amps ea.)		Output (kW)	Rated Current (amps ea.)		
		@230V	@460V		@230V	@460V		@230V	@460V	
MTML/S/H/D-3-0135	0.25	1.6	1.0	0.4	2.1	1.3	0.25/0.063	1.6/1.1	0.9/0.8	154.2
MTML/S/H/D-3-0160										200.0
MTML/S/H/D-3-0335										238.6
MTML/S/H/D-3-0360										293.5
MTML/S/H/D-3-0535										293.9
MTML/S/H/D-3-0560	0.4	2.1	1.3	0.75	3.3	2.0	0.4/0.10	2.0/1.5	1.2/0.9	371.0
MTML/S/H/D-3-1035	0.75	3.3	2.0	1.5	5.8	3.1	0.75/0.19	3.7/2.1	2.3/1.4	501.2
MTML/S/H/D-3-1060										545.2

Speed Code

- L - Designates 12 m/min
- S - Designates 24 m/min
- H - Designates 36 m/min
- D - Designates dual speed 24/6 m/min

Product code derivation - example: MTML-3-0135

- 1st M - Max-E-Lift Style
- T - Top Running
- 2nd M - Motorized
- L - Speed of 12 m/min
- 3 - Series number
- 01 - Max. Capacity - 1 Ton
- 35 - Maximum span - 35 feet (10.7m)

Imperial

SERIES 3 MAX-E-LIFT TOP RUNNING MOTORIZED

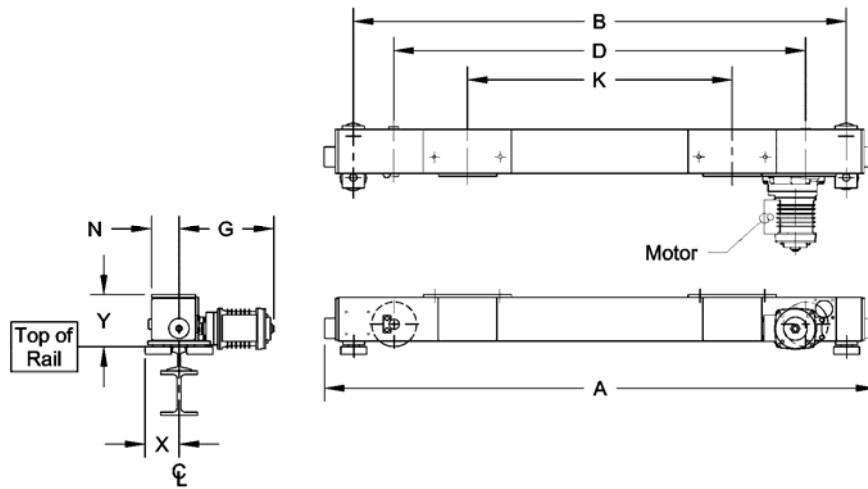

Cap. (Tons)	Max. Span (ft)	End Truck Product Code	Wheel Diameter (in)	Sug. Min. Runway Rail (ACSE#)	A Overall Length (in)	B Roller Base (in)	D Wheel Base (in)	K Beam Gauge (in)	N Runway Ctr Line to Outer Edge of ET Tube (in)	X* Width Beyond Span (in)	Y Top of Rail to Top of End Truck (in)	G Motor (in)
1	35	MTML/S/H/D-3-0135	3.74	30	72	64	54	36	2.1	4.6	7.1	12.7 (L/S) 13.1 (H) 14.0 (D)
	60	MTML/S/H/D-3-0160			111	103	93					
3	35	MTML/S/H/D-3-0335	6.10		75	67	56		3.8	4.7	9.2	13.0 (L/S) 13.4 (H) 14.3 (D)
	60	MTML/S/H/D-3-0360			112	104	93					
5	35	MTML/S/H/D-3-0535	8.27	40	75	67	56	3.5	4.7	9.3	15.0 (L/S/D) 15.4 (H)	
	60	MTML/S/H/D-3-0560			112	103	87					
10	35	MTML/S/H/D-3-1035	9.84	60	93	83	67	48	5.3	6.3	11.3	17.4 (L/S/D) 18.7 (H)
	60	MTML/S/H/D-3-1060			113	103	87					

* Based on suggested minimum runway rail.

Metric

SERIES 3 MAX-E-LIFT TOP RUNNING MOTORIZED

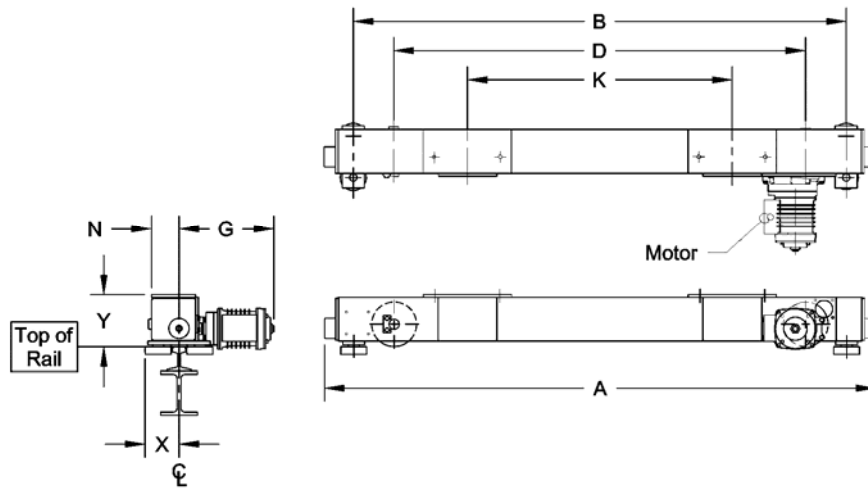

Cap. (Tons)	Max. Span (m)	End Truck Product Code	Wheel Diameter (mm)	Sug. Min. Runway Rail (ACSE#)	A Overall Length (mm)	B Roller Base (mm)	D Wheel Base (mm)	K Beam Gauge (mm)	N Runway Ctr Line to Outer Edge of ET Tube (mm)	X* Width Beyond Span (mm)	Y Top of Rail to Top of End Truck (mm)	G Motor (mm)
1	10.7	MTML/S/H/D-3-0135	95	30	1829	1626	1372	914	53	117	181	323 (L/S) 333 (H) 356 (D)
	18.3	MTML/S/H/D-3-0160			2819	2616	2362					
3	10.7	MTML/S/H/D-3-0335	155	40	1905	1702	1422	914	97	119	234	330 (L/S) 340 (H) 363 (D)
	18.3	MTML/S/H/D-3-0360			2845	2642	2362					
5	10.7	MTML/S/H/D-3-0535	210	60	1905	1702	1422	1219	89	160	287	442 (L/S/D) 475 (H)
	18.3	MTML/S/H/D-3-0560			2845	2616	2210					
10	10.7	MTML/S/H/D-3-1035	250	60	2362	2108	1702	1219	135	160	287	442 (L/S/D) 475 (H)
	18.3	MTML/S/H/D-3-1060			2870	2616	2210					

* Based on suggested minimum runway rail.

Imperial

SERIES 3 MAX-E-LIFT TOP RUNNING GEARED

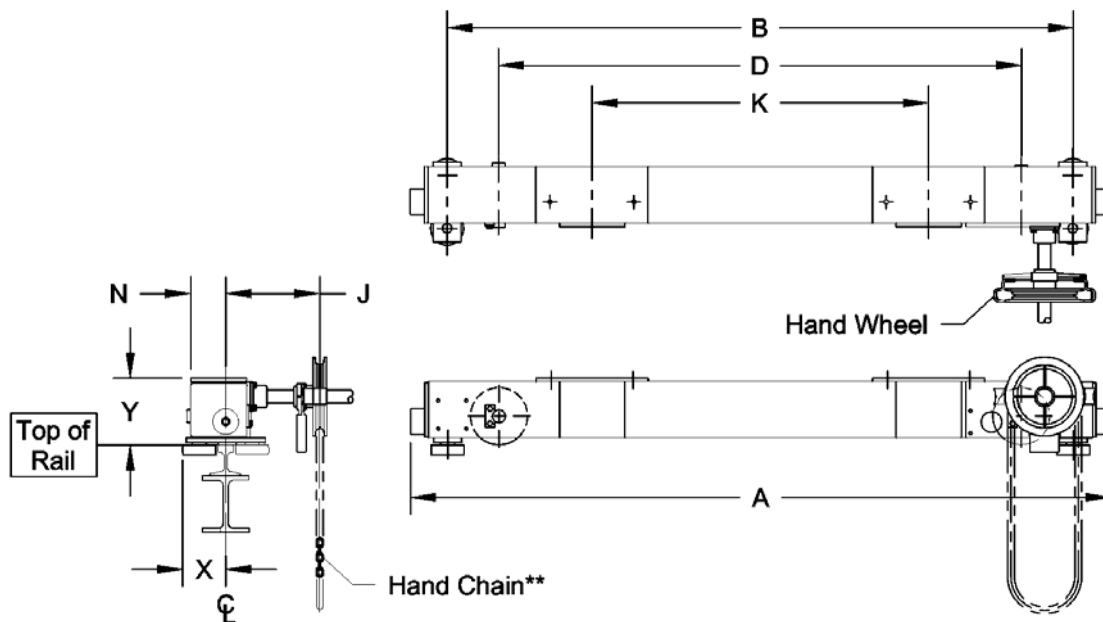

Cap. (Tons)	Max. Span (ft)	End Truck Product Code	Wheel Diameter (in)	Sug. Min. Runway Rail (ACSE#)	A Overall Length (in)	B Roller Base (in)	D Wheel Base (in)	K Beam Gauge (in)	J Hand Wheel Offset (in)	N Runway Ctr Line to Outer Edge of ET Tube (in)	X* Width Beyond Span (in)	Y Top of Rail to Top of End Truck (in)	End Truck Weight (lbs/pr)
1	35	MTG-3-0135	3.74	30	72	64	54	36	9.7	2.1	4.6	7.1	310
	50	MTG-3-0150			111	103	93						411
3	35	MTG-3-0335	6.10		75	67	56		10.0	3.8			417
	50	MTG-3-0350			112	104	93						538
5	35	MTG-3-0535	8.27	40	75	67	56	10.3	3.5	4.7	9.2	539	
	50	MTG-3-0550			112	103	87				9.3	789	

* Based on suggested minimum runway rail.

**Standard hand chain drop is 8 ft. from top of runway rail

Metric

SERIES 3 MAX-E-LIFT TOP RUNNING GEARED

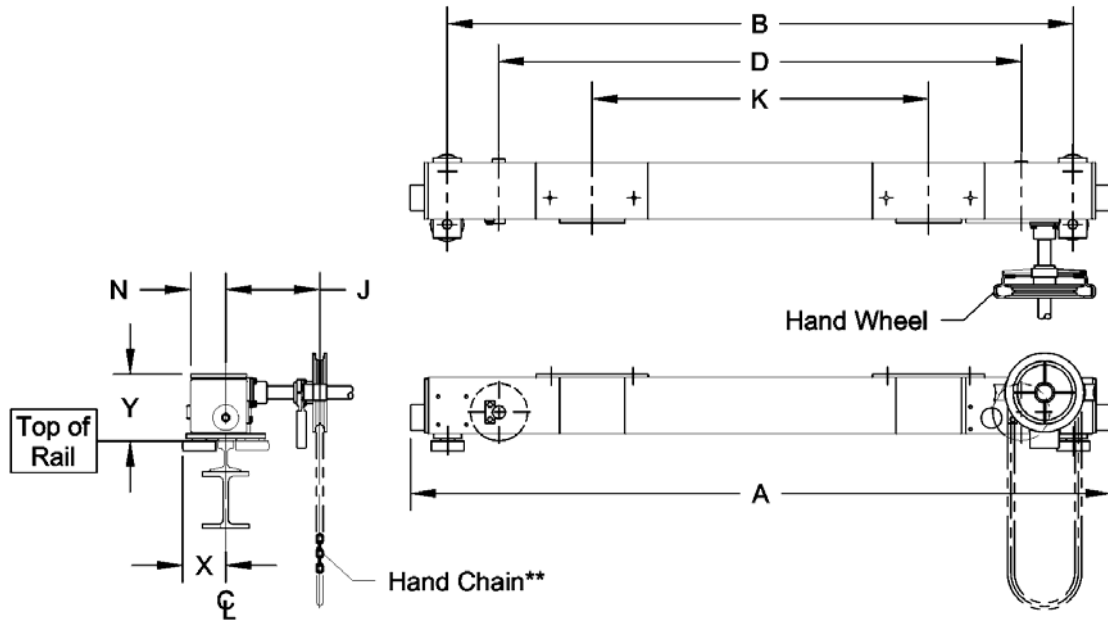

Cap. (Tons)	Max. Span (m)	End Truck Product Code	Wheel Diameter (mm)	Sug. Min. Runway Rail (ACSE#)	A Overall Length (mm)	B Roller Base (mm)	D Wheel Base (mm)	K Beam Gauge (mm)	J Hand Wheel Offset (mm)	N Runway Ctr Line to Outer Edge of ET Tube (mm)	X* Width Beyond Span (mm)	Y Top of Rail to Top of End Truck (mm)	End Truck Weight (kg/pr)	
1	10.7	MTG-3-0135	95	30	1829	1626	1372	914	246	53	117	180	140.6	
	15.2	MTG-3-0150			2819	2616	2362						186.4	
3	10.7	MTG-3-0335	155		1905	1702	1422		254	97			119	189.1
	15.2	MTG-3-0350			2845	2642	2362							244.0
5	10.7	MTG-3-0535	210	40	1905	1702	1422	262	89	119	234	244.5		
	15.2	MTG-3-0550			2845	2616	2210				236	357.9		

* Based on suggested minimum runway rail.

**Standard hand chain drop is 8 ft. (2.4m) from top of runway rail

Imperial

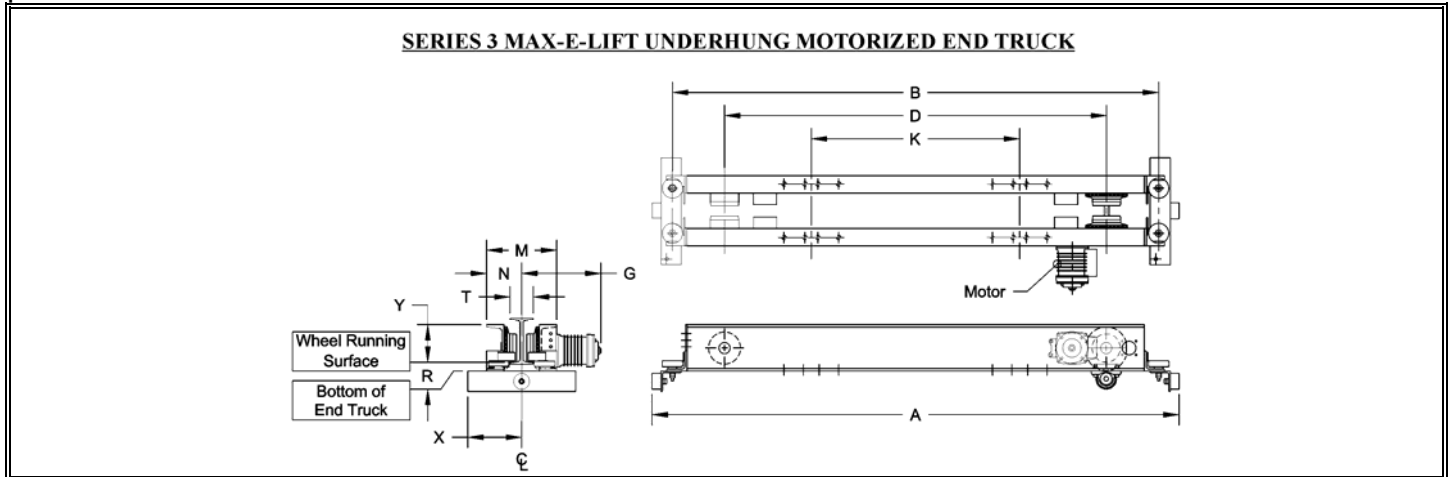

End Truck Product Code	Speed Codes L and S			Speed Code H			Speed Code D			End Truck Weight (lbs/pair)
	One Motor Per End Truck 3 Phase 60 Hz			One Motor Per End Truck 3 Phase 60 Hz			One Motor Per End Truck 3 Phase 60 Hz			
	Output (Hp)	Rated Current (amps ea.)		Output (Hp)	Rated Current (amps ea.)		Output (Hp)	Rated Current (amps ea.)		
		@230V	@460V		@230V	@460V		@230V	@460V	
MUML/S/H/D-3-0235	0.33	1.6	1.0	0.5	2.1	1.3	0.33/0.10	1.6/1.1	0.9/0.8	690
MUML/S/H/D-3-0250										765
MUML/S/H/D-3-0335										736
MUML/S/H/D-3-0350										811
MUML/S/H/D-3-0535	0.5	2.1	1.3	1.0	3.3	2.0	0.5/0.13	2.0/1.5	1.2/0.9	888
MUML/S/H/D-3-0550										973

Speed Code

- L - Designates 40 ft/min
- S - Designates 80 ft/min
- H - Designates 120 ft/min
- D - Designates dual speed 80/20 ft/min

Product code derivation - example: MUML-3-0235

- 1st M - Max-E-Lift Style
- U - Underhung
- 2nd M - Motorized
- L - Speed of 40 ft/min
- 3 - Series number
- 02 - Max. Capacity - 2 Ton
- 35 - Maximum span - 35 feet

Metric

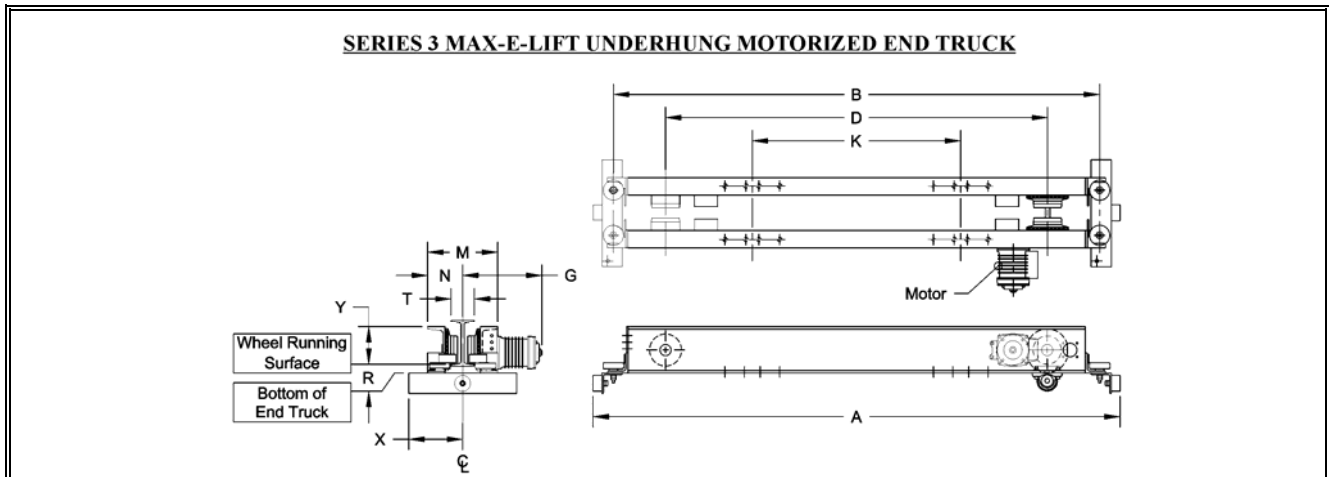

End Truck Product Code	Speed Codes L and S			Speed Code H			Speed Code D			End Truck Weight (kg/pair)
	One Motor Per End Truck 3 Phase 60 Hz			One Motor Per End Truck 3 Phase 60 Hz			One Motor Per End Truck 3 Phase 60 Hz			
	Output (kW)	Rated Current (amps ea.)		Output (kW)	Rated Current (amps ea.)		Output (kW)	Rated Current (amps ea.)		
@230V		@460V	@230V		@460V	@230V		@460V		
MUML/S/H/D-3-0235	0.25	1.6	1.0	0.4	2.1	1.3	0.25/0.063	1.6/1.1	0.9/0.8	313.0
MUML/S/H/D-3-0250										347.0
MUML/S/H/D-3-0335										333.8
MUML/S/H/D-3-0350										367.9
MUML/S/H/D-3-0535	0.4	2.1	1.3	0.75	3.3	2.0	0.4/0.10	2.0/1.5	1.2/0.9	402.8
MUML/S/H/D-3-0550										441.3

Speed Code

L - Designates 12 m/min

S - Designates 24 m/min

H - Designates 36 m/min

D - Designates dual speed 24/6 m/min

Product code derivation - example: MUML-3-0235

1st M - Max-E-Lift Style

U - Underhung

2nd M - Motorized

L - Speed of 12 m/min

3 - Series number

02 - Max. Capacity - 2 Ton

35 - Maximum span – 35ft (10.7m)

Metric

SERIES 3 MAX-E-LIFT UNDERHUNG MOTORIZED END TRUCK

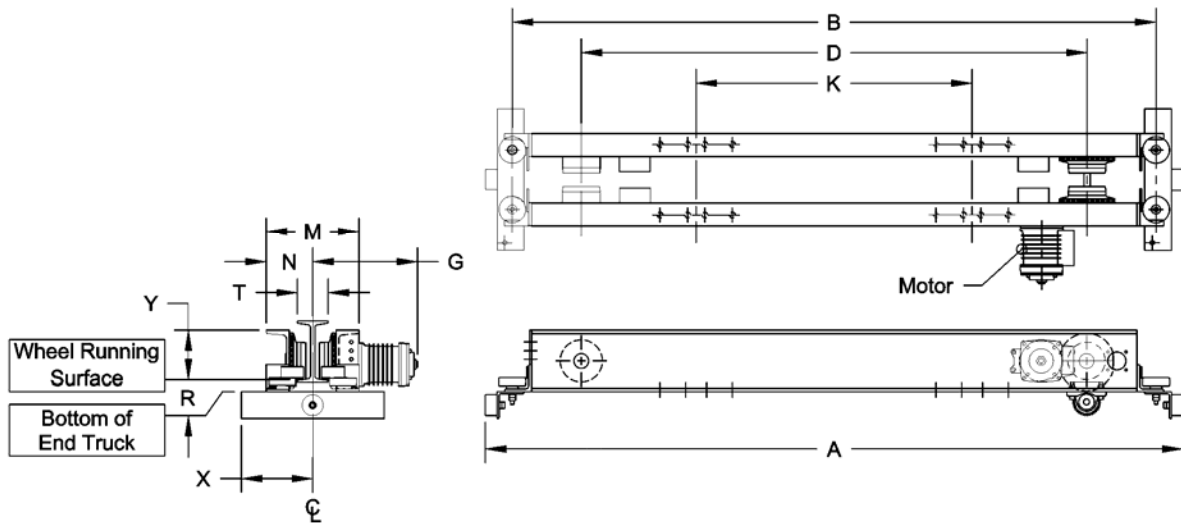

Cap. (Tons)	Max. Span (m)	End Truck Product Code	Wheel Dia. (mm)	T Flange Range Std. (mm)	A Overall Length (mm)	B Roller Base (mm)	D Wheel Base (mm)	M End Truck Frame Width (mm)	N Runway Ctr Line to Outer Edge of ET (mm)	R Wheel Running Surf. To Bottom of Truck (mm)	X* Width Beyond Span (mm)	Y Wheel Running Surface to Upper Most Part of ET (mm)	G Motor (mm)	
2	10.7	MUML/S/H/D-3-0235	110	76 - 152	2210	2032	1676	T+206		38		165	T/2+302(L/S) T/2+312 (H) T/2+338 (D)	
	15.2	MUML/S/H/D-3-0250			2515	2337	1981							
3	10.7	MUML/S/H/D-3-0335	125		2311	2134	1676	T+208						M/2
	15.2	MUML/S/H/D-3-0350			2616	2438	1981							
5	10.7	MUML/S/H/D-3-0535	140	102 - 152	2413	2235	1727	T+249		41		173	T/2+348(L/S/D) T/2 + 361 (H)	
	15.2	MUML/S/H/D-3-0550			2718	2540	2032							

* These formulas for Width Beyond Span do not apply for flanges greater than 6" (152mm). For flanges greater than 6" (152mm) consult factory.

Imperial

SERIES 3 MAX-E-LIFT UNDERHUNG GEARED END TRUCK

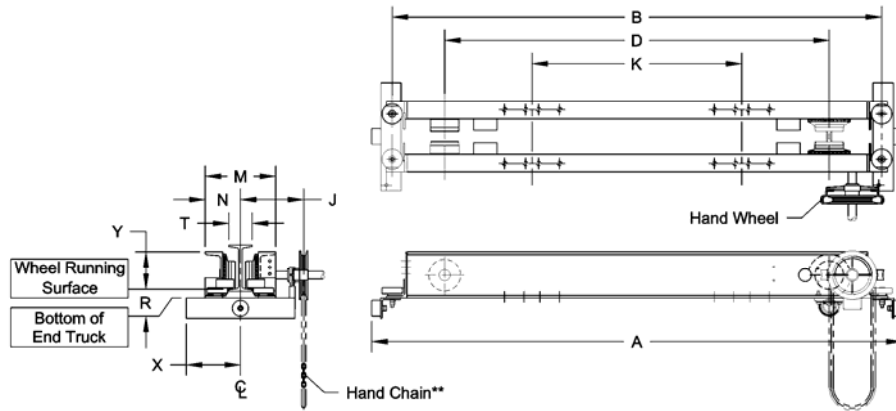

Cap. (Tons)	Max. Span (ft)	End Truck Product Code	Wheel Dia. (in)	T Flange Range Std. (in)	A Overall Length (in)	B Roller Base (in)	D Wheel Base (in)	J Hand Wheel Offset (in)	M End Truck Frame Width (in)	N Runway Ctr Line to Outer Edge of ET (in)	R Wheel Running Surf. To Bottom of Truck (in)	X* Width Beyond Span (in)	Y Wheel Running Surface to Upper Most Part of ET (in)	End Truck Weight (lbs/pr)		
2	35	MUG-3-0235	4.33	3 - 6	87	80	66	T/2+9.0	T+8.1	M/2	1.5	11.3-T/2	6.5	671		
	45	MUG-3-0245			99	92	78							746		
3	35	MUG-3-0335	4.92	3 - 6	91	84	66	T/2+8.9	T+8.2				1.5	11.3-T/2	6.7	722
	45	MUG-3-0345			103	96	78									797
5	35	MUG-3-0535	5.51	4 - 6	95	88	68	T/2+9.0	T+9.8	1.6	11.3-T/2	6.8	861			
	45	MUG-3-0545			107	100	80						946			

* These formulas for Width Beyond Span do not apply for flanges greater than 6 inches. For flanges greater than 6 inches, consult factory.

** Standard hand chain drop is 8 ft. from bottom of runway beam

Metric

SERIES 3 MAX-E-LIFT UNDERHUNG GEARED END TRUCK

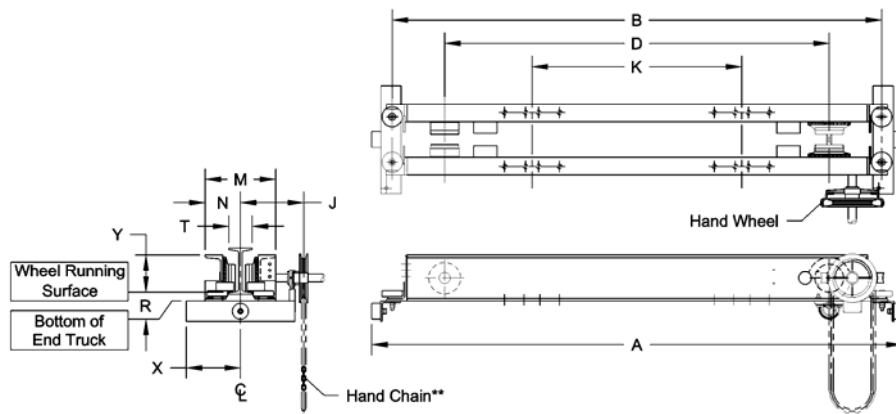

Cap. (Tons)	Max. Span (m)	End Truck Product Code	Wheel Dia. (mm)	T Flange Range Std. (mm)	A Overall Length (mm)	B Roller Base (mm)	D Wheel Base (mm)	J Hand Wheel Offset (mm)	M End Truck Frame Width (mm)	N Runway Ctr Line to Outer Edge of ET (mm)	R Wheel Running Surf. To Bottom of Truck (mm)	X* Width Beyond Span (mm)	Y Wheel Running Surface to Upper Most Part of ET (mm)	End Truck Weight (kg/pr)
2	10.7	MUG-3-0235	110	76-152	2210	2032	1676	T/2+229	T+206	M/2	38	287-T/2	165	304.4
	13.7	MUG-3-0245			2515	2337	1981							338.4
3	10.7	MUG-3-0335	125	76-152	2311	2134	1676	T/2+226	T+209	M/2	38	287-T/2	170	327.5
	13.7	MUG-3-0345			2616	2438	1981							361.5
5	10.7	MUG-3-0535	140	102-152	2413	2235	1727	T/2+229	T+249	M/2	41	287-T/2	173	390.5
	13.7	MUG-3-0545			2718	2540	2032							429.1

* These formulas for Width Beyond Span do not apply for flanges greater than 6" (152mm). For flanges greater than 6" (152mm), consult factory.

** Standard hand chain drop is 8ft (2.4m) from bottom of runway beam.

Imperial

HPC200A SERIES UNDERHUNG ENDTRUCK

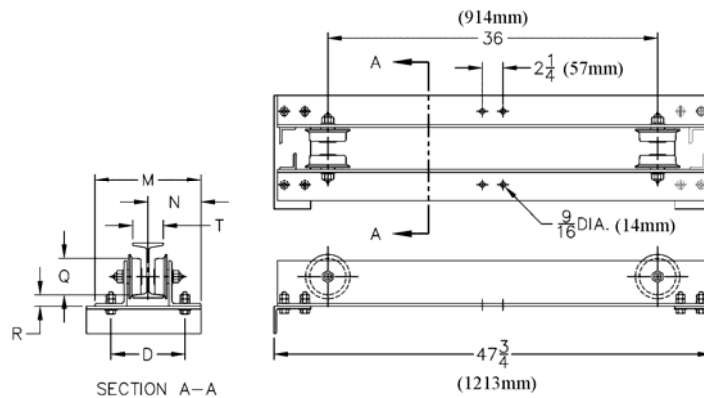

HPC200A SERIES TOP RUNNING END TRUCK

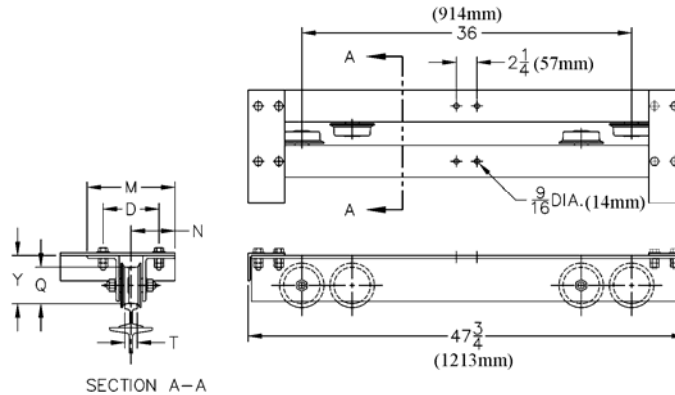

Cap. (Tons)	Max Span (ft)	End Truck Product Code	T Flange or Rail Head Width (in)		D (in)	M End Truck Frame Width (in)	N Runway Ctr Line to Outer Edge of ET (in)	Q Wheel Tread Dia. (in)	Y Wheel Running Surface to Bridge Beam (in)	R Wheel Running Surface to Bridge Beam (in)	End Truck Weight (lbs/pr)
			Top Running	Bottom Running							
1/2	24	HPC205A	1.5 - 5	3 - 5	T + 4 3/4	T + 7.3	M/2	3.12	4.3	1.2	135
1		HPC210A		3.3 - 5		T + 8.3		4.00	5.3	1.3	189
2		HPC220A							4.88	5.9	1.1

RECOMMENDED BRIDGE BEAMS

- For use with Manual Hoist only. No allowance for Electric Hoist load factor.
- Based on Harrington's manual chain hoist product.

Cap. (Tons)	Maximum Allowable Span (ft)			
	10	15	20	24
1/2	S6 X 12.5	S6 X 12.5	S7 X 15.3	S8 X 18.4
1	S6 X 12.5	S7 X 15.3	S8 X 23.0	S10 X 25.4
2	S8 X 18.4	S8 X 23.0	S10 X 25.4	S12 X 31.8

Metric

HPC200A SERIES UNDERHUNG ENDTRUCK

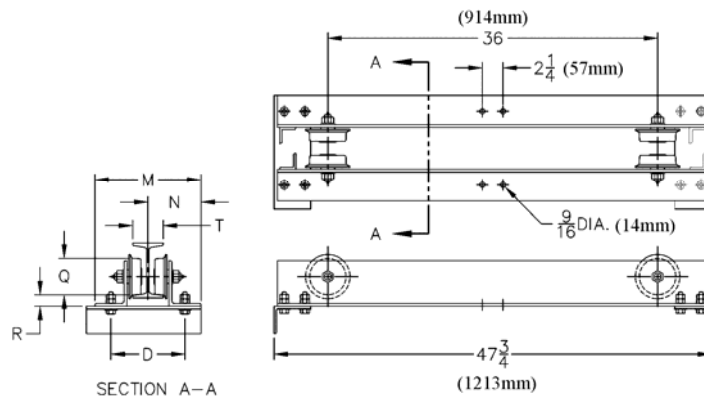

HPC200A SERIES TOP RUNNING END TRUCK

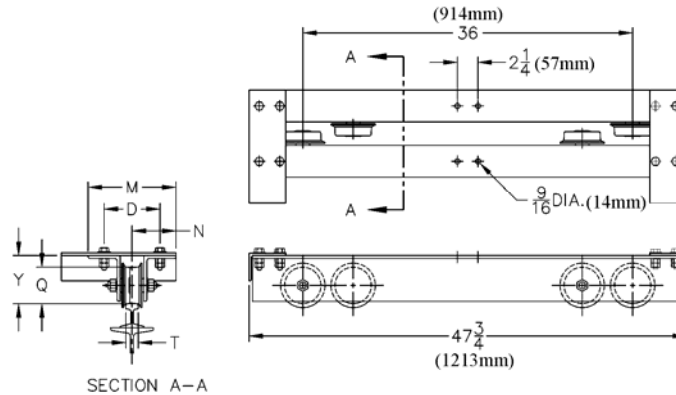

Cap. (Tons)	Max Span (m)	End Truck Product Code	T Flange or Rail Head Width (mm)		D (mm)	M End Truck Frame Width (mm)	N Runway Ctr Line to Outer Edge of ET (mm)	Q Wheel Tread Dia. (mm)	Y Wheel Running Surface to Bridge Beam (mm)	R Wheel Running Surface to Bridge Beam (mm)	End Truck Weight (kg/pr)
			Top Running	Bottom Running							
1/2	7.3	HPC205A	38 - 127	76 - 127	T + 121	T + 185	M/2	79	109	30	61.2
1		HPC210A		84 - 127		T + 211		102	135	33	85.7
2		HPC220A		84 - 127		T + 211		124	150	28	98.0

RECOMMENDED BRIDGE BEAMS

- For use with Manual Hoist only. No allowance for Electric Hoist load factor.
- Based on Harrington's manual chain hoist product.

Cap. (Tons)	Maximum Allowable Span, ft (m)			
	10 (3.0)	15 (4.6)	20 (6.1)	24 (7.3)
1/2	S6 X 12.5	S6 X 12.5	S7 X 15.3	S8 X 18.4
1	S6 X 12.5	S7 X 15.3	S8 X 23.0	S10 X 25.4
2	S8 X 18.4	S8 X 23.0	S10 X 25.4	S12 X 31.8

Imperial

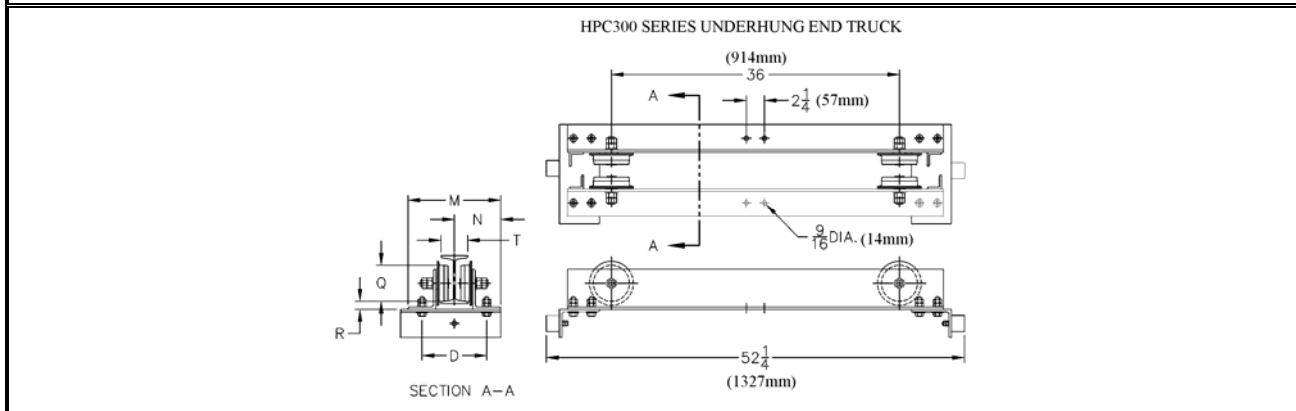
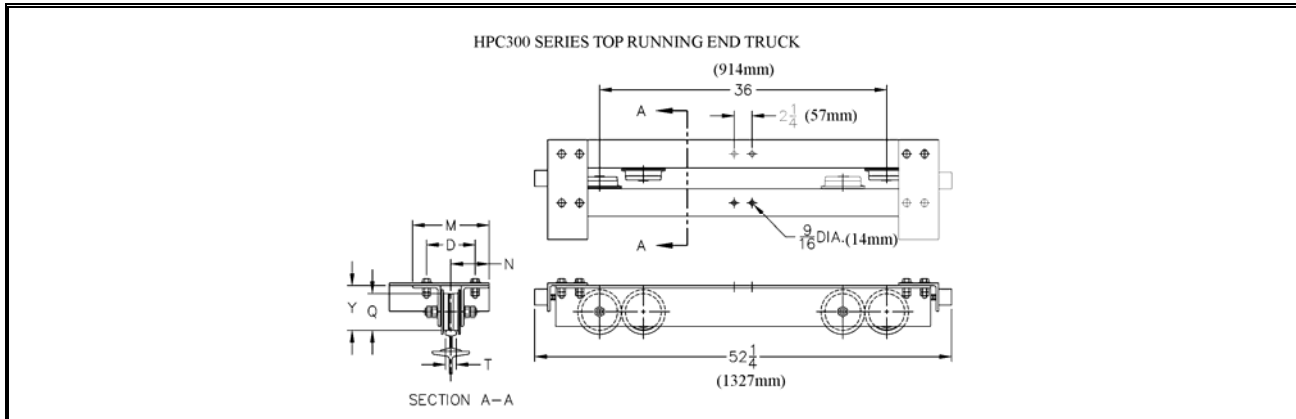

Cap. (Tons)	Max. Span (ft)	End Truck Product Code	T Flange or Rail Head Width (in)		D (in)	M End Truck Frame Width (in)	N Runway Ctr Line to Outer Edge of ET (in)	Q Wheel Tread Dia. (in)	Y Wheel Running Surface to Bridge Beam (in)	R Wheel Running Surface to Bridge Beam (in)	End Truck Weight (lbs/pr)
			Top Running	Bottom Running							
1	24	HPC310	1.5 - 5	3.25 - 5	T + 4 3/4	T + 8.3	M/2	4.50	5.5	1.0	223
2		HPC320						4.90	6.0		248

RECOMMENDED BRIDGE BEAMS				
1. Includes 15% Allowance for Electric Hoist Load Factor. 2. Based on Harrington's electric chain hoist product. 3. For spans greater than 10 ft, braces between end truck and bridge beam are recommended.				
Cap. (Tons)	Maximum Allowable Span (ft)			
	10	15	20	24
1	S8 X 18.4	S8 X 18.4	S10 X 25.4	S10 X 25.4
2	S8 X 18.4	S8 X 23.0	S12 X 31.8	S12 X 31.8 C8 X 11.5

Metric

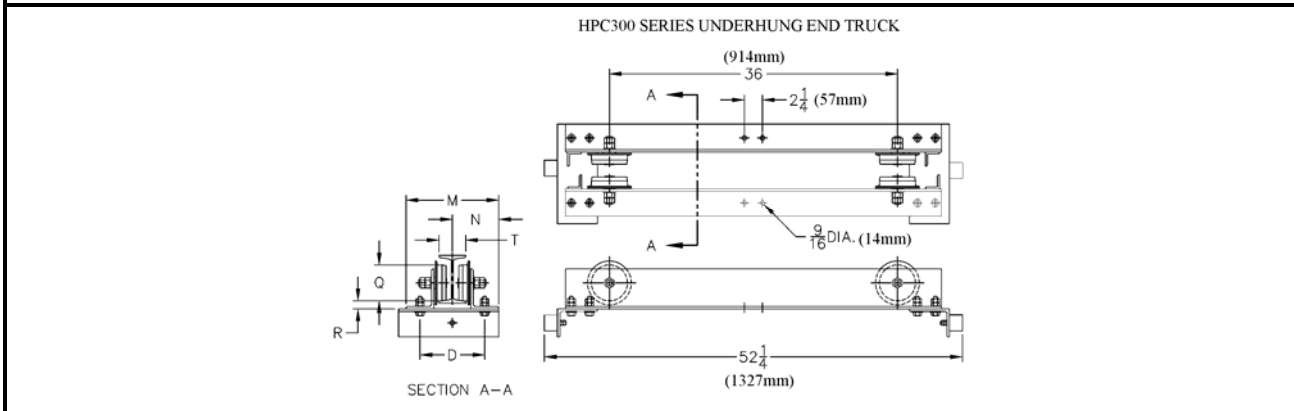
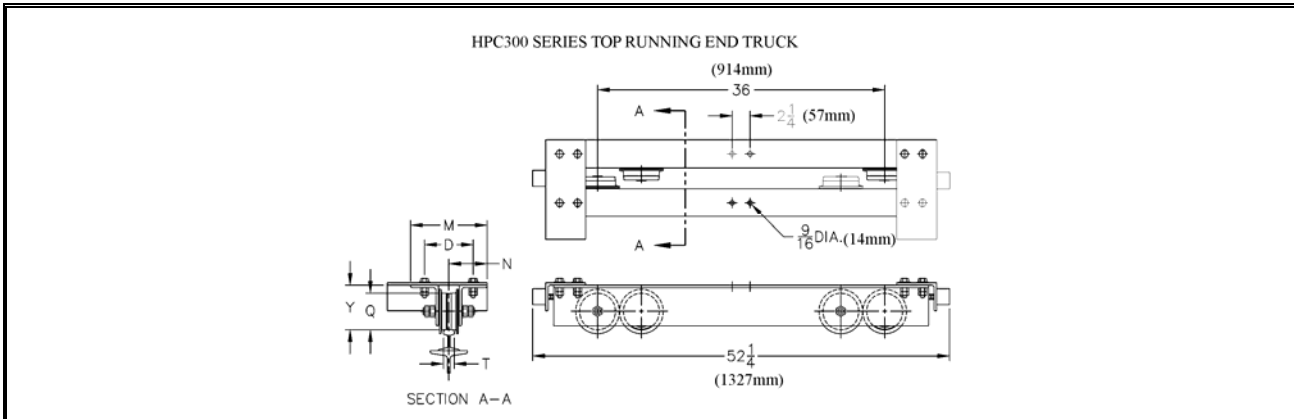

Cap. (Tons)	Max. Span (m)	End Truck Product Code	T Flange or Rail Head Width (mm)		D (mm)	M End Truck Frame Width (mm)	N Runway Ctr Line to Outer Edge of ET (mm)	Q Wheel Tread Dia. (mm)	Y Wheel Running Surface to Bridge Beam (mm)	R Wheel Running Surface to Bridge Beam (mm)	End Truck Weight (kg/pr)
			Top Running	Bottom Running							
1	7.3	HPC310	38 - 127	83 - 127	T+121	T+211	M/2	114	140	25	101.2
2		HPC320						124	152		112.5

RECOMMENDED BRIDGE BEAMS

4. Includes 15% Allowance for Electric Hoist Load Factor.
5. Based on Harrington's electric chain hoist product.
6. For spans greater than 10 ft, braces between end truck and bridge beam are recommended.

Cap. (Tons)	Maximum Allowable Span, ft (m)			
	10 (3.0m)	15 (4.6m)	20 (6.1m)	24 (7.3m)
1	S8 X 18.4	S8 X 18.4	S10 X 25.4	S10 X 25.4
2	S8 X 18.4	S8 X 23.0	S12 X 31.8	S12 X 31.8 C8 X 11.5