

Imperial Chain Container Kits:

Hoist Product Code	Kit Part Number	Max. Lift (ft)	Container Headroom D (in)	Hoist Headroom C (in)
AH250C/P	K00037	10	14.7	12.0
AH500C/P	K00038	20	16.1	

- Kit contains all components and hardware required to install the container.
- Detailed installation instructions are included in the AH Owner's Manual.
- Containers are easily installed in the field.

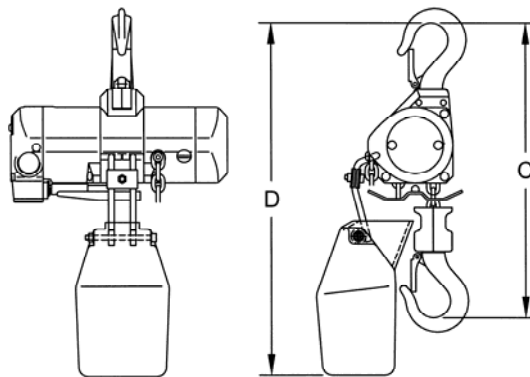

Imperial Mini Trolley:

- Trolley Product Code: ET525
- Suspenders required, part number 60456
- For use with AH250C/P and AH500C/P hoists
- Lug mount Only
- Flange range B is 1.97 to 3.94 inches. For larger flanges, hook mount the AH the Harrington's P/GTF2, ½ & 1 Ton manual trolleys using suspender C or H.
- 23.6 inch minimum allowable radius for curve

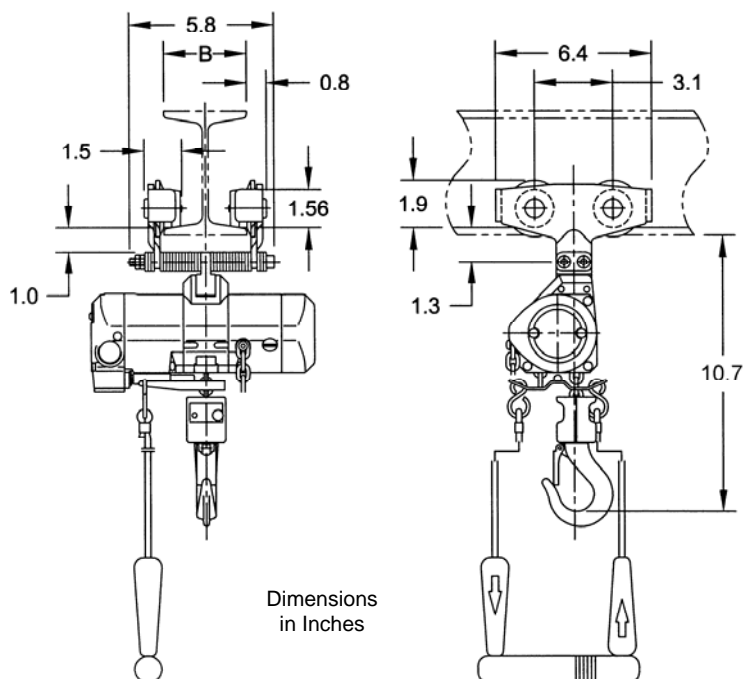

Metric Chain Container Kits:

Hoist Product Code	Kit Part Number	Max. Lift (m)	Container Headroom D (mm)	Hoist Headroom C (mm)
AH250C/P	K00037	3.0	373	305
AH500C/P	K00038	6.1	409	

- Kit contains all components and hardware required to install the container.
- Detailed installation instructions are included in the AH Owner's Manual.
- Containers are easily installed in the field.

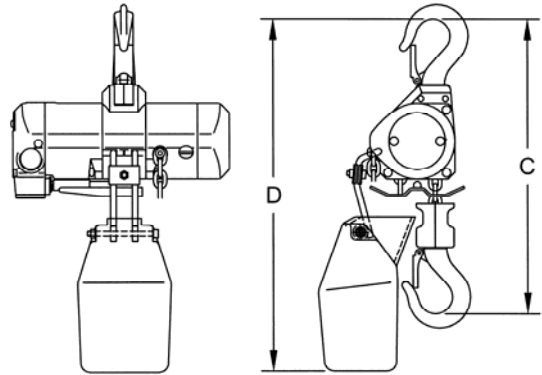

Metric Mini Trolley:

- Trolley Product Code: ET525
- Suspenders required, part number 60456
- For use with AH250C/P and AH500C/P hoists
- Lug mount Only
- Flange range B is 50 to 100 millimeters. For larger flanges, hook mount the AH the Harrington's P/GTF2, ½ & 1 Ton manual trolleys using suspender C or H.
- 600 millimeter minimum allowable radius for curve

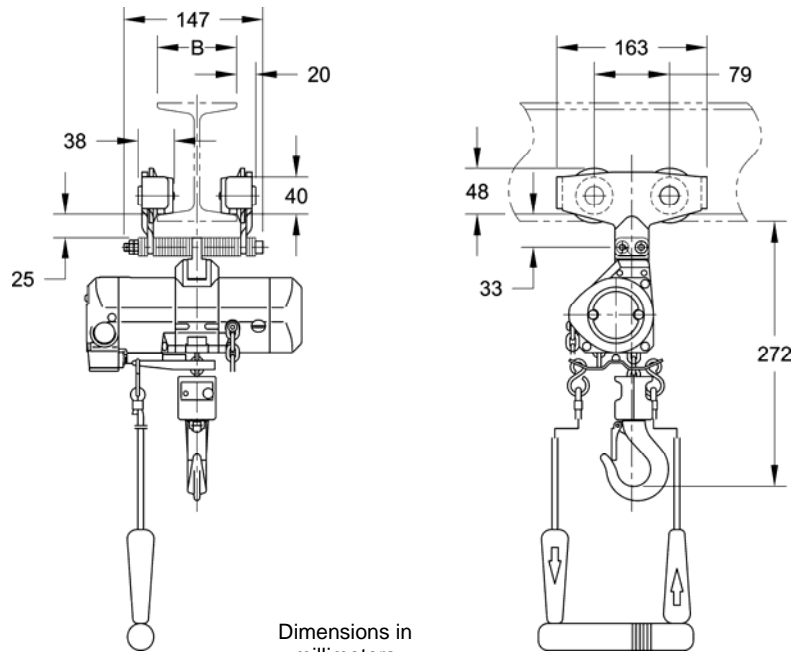

Dimensions in millimeters